



Dear Nautique Owner,

Welcome to the Nautique Family! For over 80 years, Nautique has been dedicated to providing our customers and their families with the finest inboard boats available. It's our passion to create the best performing boats in the industry. Boats that allow you to escape the routine of every day life. Our customers don't just own a Nautique, they live the Nautique life.

Your boat has been built with the best material and workmanship available, a legacy handed down from our founder. Our wealth of experience gives us the edge in innovation, quality and performance. We have the most dedicated and loyal employees in the industry. Hands down. Every day, our employees do more than just punch a clock; they take personal pride in every boat that comes down the line.

Review this Owner's Manual for your boat. We have assembled this manual to inform you about your Nautique and educate you further on boating. Please pay particular attention to the safety statements labeled as **DANGER, WARNING, CAUTION** and **NOTICE**. These statements alert you to possible safety hazards to avoid so you can have a safer boating experience. There are also many tips and tricks on care and maintenance sprinkled throughout the manual. Boating is very important to us and we would like you to enjoy many years of boating in your Nautique.

By purchasing a Nautique, you have taken the first step in trading your old lifestyle for a new one. Now that you own a Nautique, life as you know it will never be the same.

Enjoy the Nautique Life.

The Nautique Team

Keep your heart with all diligence,
for out of it spring the issues of life.

Proverbs 4:23

Record Important Information

In addition to this manual, your Nautique boat is supplied with component manufacturer information such as instructions, warranties or other important information. Read these materials carefully since improper operation and maintenance can void the warranty and jeopardize personal safety.

Safeguard information about your Nautique boat by recording the Hull Identification Number (HIN) and the model of your boat and the model and serial numbers of your engine/transmission and trailer, if applicable.

Your HIN is located on the top right side of the transom, above the water line. The U.S. Coast Guard requires that your HIN be permanently affixed and remain on the top right side of the transom. The first three digits represent the Nautique manufacturer, Correct Craft, Inc. (CTC) The next five digits are the boat's serial number. The next digit is a letter from "A" where "A" = January through "L" where "L" = December, designating the month the boat was made.

The last three digits represent the last digit of the year the boat was built and the final two digits of the boat model year. A boat built in July 2006 is actually a 2007 model boat. Example: A boat with "607" as the last digits indicates the boat was built in 2006, but it is a 2007 model boat.

Hull

HIN _____
Date Purchased _____
Dealer/Phone _____
Ignition Key Number _____
Registration Number/State _____

Engine

Model Number _____
Serial Number _____

Trailer

Model Number _____
Serial Number _____

Accessory

Model Number _____
Serial Number _____

The identification numbers are important! Keep a copy of these numbers stored in a safe place off the boat. In case of theft, damage, etc., report these numbers to the local authorities, your insurance agent and your Nautique dealer.



Boater's Checklist

For improved safety and enjoyment, check each of these items:

Check Before You Launch Your Boat:

- Read both the engine and the boat operator manuals.
- Drain plug (Securely in place?)
- Propeller Condition (Prop nut tight and secured, no cracked or bent blades, prop turns freely?)
- Steering System (Working smoothly and properly, self locking nuts in place?)
- Battery (Fully charged, cable terminals clean and tight?)
- Capacity Plate (Are you overloaded?)
- Weather conditions (Safe to go out?)
- Fuel and Oil (Sufficient for trip, check bilge area for gas odor, no leaks?)
- Hoses and Connectors (No leaks or damage?)
- Electrical Equipment (Lights, horn, pumps, etc.?)
- Safety Equipment (Fire extinguisher, bailer, paddle, anchor and line, mooring lines, signaling device, tool kit, first aid kit, first aid manual?)
- Personal Flotation Devices for all occupants
- Float Plan submitted to Responsible Person (Verbal or written?)

Check Before You Start Your Engine:

- Fuel (Sufficient for trip, check bilge area for gas odor?)
- Control Lever in Neutral
- Capacity Plate (Are you overloaded?)
- Personal Flotation Devices for all occupants
- Seating (Everyone in proper place?)
- Engine Stop Switch and Lanyard (Operational and securely fastened?)
- No one in water near boat
- Keep firm and continuous grip on steering wheel
- Engine Cooling Water Valve open



Restricted Areas

Before boating, check with Local, State and Federal authorities to identify restricted areas. Because of the threat of terrorism, the U.S. Coast Guard has and will continue to implement strict limits on watercraft near U.S. Navy and Coast Guard ships and other potential targets.

Proposition 65

▲ WARNING

A wide variety of components used on this vessel contain or emit chemicals known to the State of California to cause cancer and birth defects and other reproductive harm.

EXAMPLES INCLUDE:

Engine and generator exhaust.
Engine and generator fuel, and other liquids such as coolants and oil, especially used motor oil.
Cooking fuels.
Cleaners, paints and substances used for vessel repair.
Waste materials that result from wear of vessel components.
Lead from battery terminals and from other sources such as ballast or fishing sinkers.

TO AVOID HARM:

Keep away from engine, generator and cooking fuel exhaust fumes.
Wash area thoroughly with soap and water after handling the substances above.

California Health & Safety Code 25249.5-.13

KC-0206-B

Emission Control Warranty Information



CORC013

The engine in your Nautique boat meets the strict requirements set forth by the California Air Resources Board (CARB). The engine has a special environmental tag and the boat has this label affixed to it. The tag and the label are required by the California Air Resources Board (CARB). The label has 1, 2, 3 or 4 stars. The label **MUST** be affixed to the boat, if the boat is operated in the state of California and/or bordering waters.



Boating Terminology

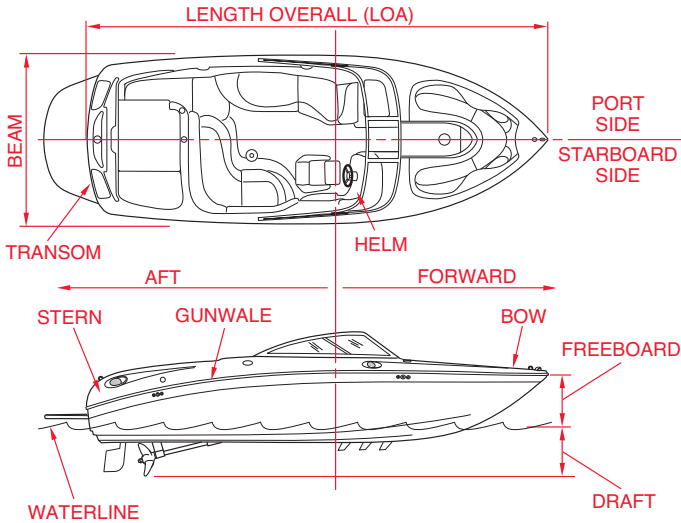

CORC001

* An easy way to remember PORT side from STARBOARD side is “PORT” and “LEFT” both have four letters.

Product Improvement

Because of our policy of continuous product improvement, the illustrations used in this manual may not look the same as on your boat and are intended only as representative reference views. Some illustrations may also show optional accessories which may or may not be available for your boat. Many optional accessories can only be installed at the time the boat is manufactured and cannot be installed by your dealer. Your dealer will be happy to provide details on installing accessories.



Table of Contents

Welcome	i	Fire Suppression	
Record Important		Equipment	1-18
Information	ii	Visual Distress Signals	1-19
Boater's Checklist	iii	Recommended Safety	
Restricted Areas	iv	Equipment	1-21
Proposition 65	iv	Emergency Stop Switch and	
Emission Control Warranty		Lanyard	1-22
Information	iv	Emergencies	1-23
Boating Terminology	v	Fire/Explosion	1-23
Product Improvement	v	Capsizing and	
Boating Safety	1-1	Swamping	1-24
Safety While Boating	1-1	Collisions	1-24
General Precautions	1-3	Grounding	1-24
Boat Safety Labels	1-5	Water Rescue	
Boating Regulations	1-8	(Man Overboard)	1-24
Boater Responsibilities	1-8	Medical Emergency	1-25
Registration/		Operation Failure	1-25
Documentation	1-9	Hazardous Conditions	1-25
Insurance	1-10	Shallow Water	
Education Opportunities	1-10	Operation	1-25
Operating By Minors	1-11	Weeds	1-25
Overloading	1-11	Dam Spillways	1-26
Passenger Safety and		Weather/Seas	1-26
Seating	1-13	Warning Markers	1-27
Visibility	1-13	Carbon Monoxide	1-28
Boating Under the		Our Environment	1-29
Influence	1-14	Foreign Species	1-29
Reporting Accidents	1-15	Fuel/Oil Spillage	1-29
Rendering Assistance	1-15	Discharge/Disposal of	
Required Safety		Waste	1-30
Equipment	1-15	Excessive Noise	1-30
Life Saving Equipment	1-16	Wake/Wash	1-30
Navigation Lights	1-18	Exhaust Emissions	1-30
Horn or Whistle	1-18	Paints	1-30
Fire Extinguisher	1-18	Cleaning Agents	1-31
		MARPOL Treaty	1-31



Watersport Safety.....	1-31	Shifter/Throttle.....	4-4
Teak/Drag Surfing.....	1-31	Emergency Stop Switch	4-5
General Watersport		Dash Pod	4-6
Precautions	1-33	Gauges.....	4-6
Watersports Responsibility		Speedometer Calibration	4-8
Code	1-36	Control Switches.....	4-8
Basic Rules of the Road.....	2-1	12-Volt Port	4-8
Aids to Navigation	2-1	Ignition Keyswitch	4-8
USWMS System	2-2	Dash Pod	4-12
Uniform State Regulatory		Ignition and Switch	
Markers.....	2-3	Panel	4-12
FWMS System	2-3	Nautique Cruise	
Right of Way.....	2-5	Control	4-17
Privileged Boats	2-5	Gauges.....	4-20
Burdened Boats.....	2-5	Tachometer/Fuel	
Crossing Situation	2-6	Monitor	4-27
Meeting Head-On	2-7	Power Management	
Overtaking	2-8	Access (PMA) Panel.....	4-32
The General Prudential		Bilge.....	4-32
Rule.....	2-9	12-Volt Recpt.....	4-32
Night Running.....	2-9	12-Volt Port	4-32
Crossover Nautique		Circuit Breakers.....	4-32
216V/226	3-1	Battery Selector Switch	4-33
Specifications	3-1	Dash Pod Circuit	
216V.....	3-1	Breaker Box	4-34
226	3-2	Standard Equipment.....	4-35
Dash Pod and Console.....	3-3	Watersports Tow Point.....	4-35
Ignition and Switch Panel.....	3-4	Bow Features of Your	
Keys	3-5	Nautique	4-36
216V Deck Layout	3-6	Driver's Seat	
226 Deck Layout	3-8	Adjustment.....	4-37
Standard and Optional		Rearview Mirror	
Equipment	3-10	Adjustment	4-38
Controls and Indicators	4-1	Observer's Seat	4-39
Steering.....	4-1	Storage Hatch	4-39
Hydro-Gate™ Control and		Engine Cover Hatch	4-40
SportShift™.....	4-2	Walk-Thru Windshield	
		Opening/Latching.....	4-41
		Coolers	4-41



Boarding Platform	4-42	Shifting	6-14
Engine Cooling Water		Steering	6-14
Intake Valve.....	4-43	Stopping	6-15
Fuel Tank	4-45	Docking	6-15
Folding Instructions for Flight Control Tower™ – Optional	4-46	Running.....	7-1
Anchor Storage Locker ...	4-47	Maneuvering Techniques	7-2
Engine Compartment		Tow Pattern	7-3
Air Intakes.....	4-48	Freezing Temperatures	7-4
Bimini Top	4-48	Anchoring	7-4
Ballast Tanks	4-50	Dropping Anchor.....	7-5
Optional Accessories	4-51	Weighing (Pulling In)	
Stereo and Speaker		Anchor.....	7-6
Pods	4-51	Performance Boating.....	7-7
Boat Systems	5-1	Propellers	7-7
Fuel System.....	5-1	Care and Maintenance	8-1
Ballast Tanks and Bilge System	5-3	General Maintenance.....	8-1
Ballast Tank Valves - 216V.....	5-4	Engine Intake Water	
Ballast Tank Valves - 226	5-4	Strainer.....	8-2
Belly Ballast Tank and Bilge System	5-5	Bilge Pumps	8-3
Port and Starboard Ballast Tank	5-6	CE Bilge Discharge Filter.....	8-4
12 Volt System	5-7	Cartridge Replacement.....	8-4
Heater System-Optional.....	5-8	Propeller.....	8-5
Getting Underway	6-1	Removal.....	8-5
Safety Checklist.....	6-1	Installation	8-6
Safety Equipment	6-2	Propeller Shaft Stuffing	
Fueling.....	6-2	Box.....	8-7
Gasoline Containing		Through-Hull Fittings	8-7
Alcohol	6-3	Quick Oil Drain System	8-7
Boarding.....	6-5	Salt Water Boating.....	8-8
Boat Planing.....	6-5	Fresh Water Flushing Kit- Optional	8-8
Pre-Operation Checks.....	6-6	Proper Use of Freshwater	
Flooded Engine	6-11	Flushing Kit.....	8-8
Break In Procedure.....	6-13	Battery Maintenance	8-9
Propeller Selection.....	6-13	Gelcoat Maintenance	8-11
		Care of Metal	8-12
		Care of Glass	8-12
		Vinyl Maintenance and Cleaning	8-13



Tunable Rudder.....	8-15
Rudder Remote Lube Fitting	8-16
Transmission	8-17
Shift Cable.....	8-18
Troubleshooting	9-1
Trouble Check Chart	9-2
Performance	9-2
Electrical.....	9-3
Storage	10-1
Lifting Rings and Lifting Eyes	10-1
Winterizing Your Boat.....	10-3
Check for Water in Your Fuel System	10-5
Winterizing Ballast Tanks (if equipped).....	10-6
Trailer/Trailerling	10-7
Hitch.....	10-7
Wiring.....	10-7
Security.....	10-7
Towing Your Boat.....	10-8
Long Trips.....	10-9

Glossary	G-1
Warranty.....	W-1
CORRECT CRAFT LIMITED WARRANTY.....	W-1
Lifetime Limited Warranty.....	W-1
Transferable Lifetime Limited Warranty.....	W-1
Boat Five (5) Year Transferable Limited Warranty.....	W-2
Gelcoat Three (3) Year Non-transferable Limited Warranty.....	W-2
Engine Warranty	W-2
Request for Transfer of Warranty on Parts.....	W-5
Request for Warranty Transfer of Hull, Deck, and Stringer	W-6
Nautique Regional Centers	W-7



NOTES





Section I Boating Safety

Safety While Boating

Boating-related accidents are generally caused by the operator's failure to follow basic safety rules or written precautions. Most accidents can be avoided if the operator is completely familiar with the boat, its operation and can recognize potentially hazardous situations.

In addition to everyday safety, failure to observe the safety recommendations may result in severe personal injury or death to you or to others. Use caution and common sense when operating your boat. Do not take unnecessary chances! Remember that at least three people are needed for safely towing watersport participants.

Failure to adhere to these warnings may result in severe injury or death to you and/or others.

- **Look before you turn the boat. As a boater you are obligated to maintain a course and speed unless it is safe to alter course and speed. Look before you turn.**
- **Improper operation of the boat is extremely dangerous. Operators must read and understand all operating manuals supplied with the boat before operation.**
- **On-board equipment must always conform to the governing federal, state and local regulations.**
- **Prior to starting the engine, you MUST open the engine box and check the engine compartment and bilge for gasoline and oil vapors. You MUST also operate the blower for at least four minutes. Failure to do so may result in fire or explosion. If you smell gasoline vapor or see liquid gasoline, DO NOT start the engine.**

Section I

- **DO NOT** operate the boat while under the influence of alcohol or other drugs.
- **DO NOT** stand or allow passengers to stand in the boat, or sit on the transom, seat backs, engine cover or sides of the boat while the engine is running. You or others may be thrown from the boat.
- **DO NOT** allow any type of spark or open flame on board. It may result in fire or explosion.
- **DO NOT** leave children in the boat without adult supervision.
- **DO NOT** sit in front of the operator to avoid obstructing the operator's view.
- **DO NOT** dive from the boat without being absolutely sure of the depth of the water, otherwise severe injury or death may occur from striking the bottom or submerged objects.
- **DO NOT** swim near the boat when the engine is running. Being in NEUTRAL is not enough, the propeller may still be turning and carbon monoxide may be present.
- **DO NOT** replace your boat's marine parts with automotive parts.
- **DO NOT** remove or modify any components of the fuel system except for maintenance by qualified personnel. Tampering with fuel components may cause a hazardous condition.
- **DO NOT** wrap ski lines or mooring lines around any body part which may become entangled in the line if you fall overboard and the boat is moving.
- Keep track of ski lines and dock lines so they do not become entangled in the propeller.
- Be sure to securely attach the engine emergency stop switch lanyard to a part of your clothing, such as a belt loop, when operating the boat.
- Be sure to keep a watch for other boats, swimmers and obstructions in the water. Stay away from other boats and personal watercraft.
- Be sure to have an experienced operator at the helm and always have at least three people present for safe towing – one to drive, one to observe and one to ski or ride.



- Seek shelter from open water if there is threat of lightning.
- Operate slowly in congested areas such as marinas and mooring areas.
- The bow may be slippery. Do not go forward while the engine is running.
- When you leave the boat take the keys with you. This will keep untrained and unauthorized persons from operating the boat.
- Engine exhaust contains carbon monoxide.
 - DO NOT operate the engine in a confined space.
 - DO NOT go under the boat cover with the engine running or shortly after the engine has been running.
 - DO NOT use boarding platform with the engine running.
 - DO NOT “teak surf.”
 - Allow adequate ventilation with fresh air before entering.
 - Slow down when crossing waves or wake in order to minimize the impact on passengers and the boat.

General Precautions

Your safety and the safety of your passengers and other boaters are among your responsibilities as operator of this boat. Your boat must be in compliance with USCG safety equipment regulations. You should know how to react correctly to adverse weather conditions, have good navigation skills, and follow the “Rules of the Road” as defined by the USCG and state/county/local regulations.

Before each outing you should check all safety equipment, such as fire extinguishers, PFDs, flares, distress flags, flashlights and emergency stop switch. They should be operable, in good condition, readily visible and easily accessed.

Know the weight capacity of your boat. DO NOT overload your boat.

This section covers general boating safety information. Throughout this manual specific precautions and symbols identify safety related information.



Section I



The Safety Alert Symbol means ATTENTION! BECOME ALERT! YOUR SAFETY IS INVOLVED!



DANGER Indicates a hazardous situation, which, if not avoided, will result in death or serious injury.



WARNING Indicates a hazardous situation, which, if not avoided, could result in death or serious injury.

CAUTION

Indicates a hazardous situation, which, if not avoided, may result in minor or moderate injury.

NOTICE

Indicates a property damage message.

The precautions listed in this manual and on your Nautique boat are not all-inclusive. If a procedure, method, tool, or part is not specifically recommended, you must satisfy yourself that it is safe for you and others, and that the boat will not be damaged or made unsafe as a result of your decision. REMEMBER - USE COMMON SENSE WHEN OPERATING YOUR BOAT!



Boat Safety Labels

Your Nautique boat is affixed with various safety labels at the time of manufacture. These labels appear at specific locations on the boat where safety is of particular concern. Safety labels must be legible. If you suspect a label is missing or one becomes damaged, contact your Nautique dealer for immediate replacement.

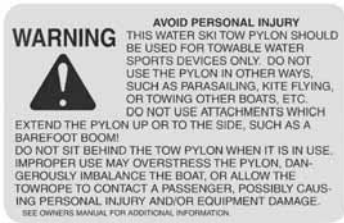

Tow Pylon



Engine Inside Box and on Fuel Tank

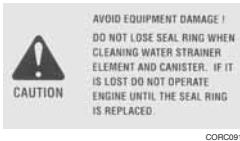

Water Strainer



Fuel Fill

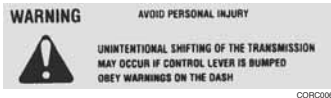

Throttle Control

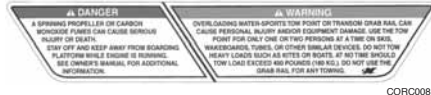

Transom Warning

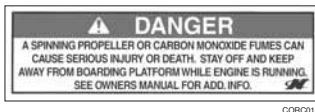

Cross Member/Boarding Platform



Engine



Section I



CORC093

Flame Arrestor



CORC094

Board Racks

CAUTION: TO AVOID INJURY, WINDOW MUST BE SECURED IN THE CLOSED POSITION WHEN VESSEL IS IN MOTION. USE BOTH WINDOW LOCKS.

CORC064

Walk Through Windshield

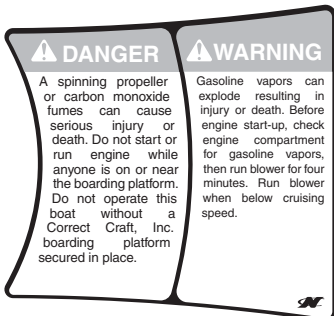

CORC203A

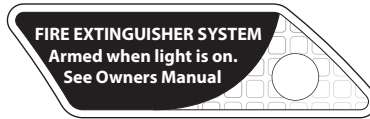

CORC204

Dash Pod



Fuel Control Cell

OPERATOR INSTRUCTIONS

Caution: Visually inspect unit for leakage before operating engine. If leakage is present, do not operate engine. Contact service technician immediately.

SERVICE INSTRUCTIONS

Danger: Improper installation or use may cause explosion/fire resulting in bodily injury or death. Service only by a qualified technician. Read/follow all instructions. Run engine & check for fuel leakage after installation, replacing element or draining bowl. Do not remove bowl except during element change or contamination, operation, or bowl drying; swelling may result. Frequency of water draining or element replacement is determined by contamination level in fuel. Replace element at least once a year or when power loss occurs, whichever comes first.

To Drain Water: With Engine Off

1. Disconnect two wire electrical harness.
2. Remove 7/16 brass plug. Drain water into container.
3. Apply pipe sealant suitable for gasoline to 7/16 brass plug.
4. Insert into canister. Tighten 7/16 brass plug.
5. Cycle ignition key several times to prime electric fuel pumps and fill canister with fuel. Inspect drain for leaks.
6. Start engine and inspect for leaks.

To Replace Element: With Engine Off

1. Disconnect two wire electrical harness.
2. Remove 7/16 brass plug. Drain water into container.
3. Remove canister by turning with oil filter wrench.
4. Slide canister downward over the suspended filter element. It may be necessary to pull the unit to one side to remove.
5. Remove fuel filter element from the suspended pump by pulling the filter downward.
6. Visually inspect all internal components, i.e. hoses, wires, etc.
7. Push on new fuel filter element over electric fuel pump.
8. Remove old O-ring from the head of the canister.
9. Install new O-ring in the same location. Lubricate the O-ring with a light oil.
10. Apply pipe sealant suitable for gasoline to 7/16 brass plug.
11. Insert into canister. Tighten 7/16 brass plug.
12. Grease threads on canister. Tighten firmly. Back into head with oil wrench.
13. Cycle ignition key several times to prime electric fuel pumps with fuel. Inspect drain for leaks.
14. Start the engine and inspect for leaks.

PATENT# 5,740,784 • 6,112,725 • 5,358,001

WARNING: DO NOT ATTEMPT TO SERVICE ANY OTHER PARTS ON THIS UNIT!

R143112

CORC095

Fuel Control Cell

⚠ DANGER

Failure to follow these guidelines can result in injury or death. Do not tow more than two persons at one time from this tow tower. The tow tower should only be used for waterskis, wakeboards, or recreational towables and not for parasailing, kite flying, or towing other boats, etc. Do not add any attachments that are not installed by Correct Craft, Inc. Do not climb on, sit on, stand on, jump off, or dive off the tow tower. Never allow passengers to sit behind the towrope attachment point. Never allow loose towrope ends to dangle. Always be certain that all bolts are in place and tight before and during use. When the tower is up watch for low obstacles such as tree limbs, bridges, or power lines. Before trailering your boat make sure that the tow tower is in the down position and properly secured.

CORC011

Flight Control Tower™

⚠ WARNING

Avoid personal injury

- ⚠ Never let engine reach the coast. (Do not backed facing forward with hands on the controls.)
- ⚠ Caution fuel to a fire and explosion hazard. Inspect fuel system regularly and fix leaks immediately.
- ⚠ Do not sit on seat banks, boat sides, or engine box while engine is running. Do not stand on boat sides at any time.
- ⚠ Do not make high speed maneuvers in this boat.
- ⚠ Always test the emergency engine shut off switch for proper function before operating the boat and never operate the boat unless the lanyard is securely attached to the driver.
- ⚠ Always empty all ballast systems before lifting or hoisting boat.
- ⚠ Do insure safe use and maintenance of this boat, read and understand the owners manual thoroughly. If you do not have a manual, contact: Correct Craft, Inc., 14700 Neeropace PKWY, Orlando, FL 32809 (407) 855-4141. sk@skboatworks.com

Note: Enhancement ballast tank system in some models. The full

weight of this system has already been considered in the boat weight and therefore does not influence maximum capacity, unlike portable ballast tanks or weights, which must be included as part of the gear weight.

CORC200

Side Console



Section I

Boating Regulations

The U.S. Coast Guard (USCG) is the authority of the waterways; they are there to help the boating public. State boating regulations are enforced by local authorities. You are subject to marine traffic laws and “Rules of the Road” for both federal and state waterways; you must stop if signaled to do so by enforcement officers, and permit to be boarded if asked.

There are many pamphlets, prepared by the USCG, available to you. These pamphlets explain “Rules of the Road,” signal lights, buoys, safety, international and inland regulations and much more than is presented in the manual. For more information, contact your local USCG Unit or visit <http://www.uscgboating.org>.

Boater Responsibilities

It is the owner’s responsibility to ensure that the operator of the boat has been properly instructed in the lawful and safe operation of this vessel. Therefore, before operating the boat, read this owner/operator manual. Be sure you understand each item before operating it. Improper operation or trailering of the boat could lead to severe damage and/or injury.

At the time of delivery, the owner/operator is responsible for:

- Understanding warranty terms and conditions of your boat, your engine and your trailer.
- Obtaining insurance.
- Examining boat to ensure proper operation of all systems.

Before operating the boat, the owner/operator is responsible for:

- Obtaining state registration of the boat.
- Providing the proper USCG required safety equipment.
- Following proper break-in procedure for the engine.
- Understanding safety information and proper operating procedures within this manual.



While operating the boat, the owner/operator is responsible for:

- Knowing that all safety equipment and personal flotation devices (PFDs) are in good condition and suitable for your boat and passenger load.
- Knowing that the capacity of the load are within the limits stated on the USCG Maximum Capacities Plate.
- Verifying that the emergency stop switch is in proper operating condition.
- Ensuring that all passengers are properly and securely seated in appropriate seating locations.
- Following safe operating practices and the “Rules of the Road.”
- Understanding proper maintenance and knowledge of the boat’s operating systems.
- Providing safety training for the passengers.
- Having at least one other passenger who is capable of handling the boat in an emergency.
- Maintaining a proper lookout by sight and hearing.
- Avoiding use of alcohol and other drugs.
- Providing assistance to other boaters.

Registration/Documentation

The USCG requires that all power boats operated on the navigable waters of the U.S. must be registered in the state of main use; also, many states require registration in that state whenever boating on waters within their state boundary. Contact your state boating authorities (and neighboring states) for registration information on boats and trailers. Your Nautique dealer can supply you with the appropriate forms.



Section I

Insurance

You must get insurance before operating your new boat. Insurance for loss by fire, theft or other causes, or liability protection against accidents is a must for responsible boaters. The boat owner is legally responsible for any damage or injury caused when he, or someone else operating the boat, is involved in an accident. Many states have laws detailing minimum insurance needs. Your insurance agent or your Nautique dealer may be able to supply you with more information.

Education Opportunities

This manual is not intended to provide complete training on all aspects of boat operation. We strongly recommend that all operators of this boat seek additional training on boat handling and safety. Have all operators become familiar with the handling characteristics, and proper steering and control system usage before attempting high speed operation.

Some states require youths 16 years of age and younger to complete a boating safety course before operating any watercraft. Many others require operators under the age of 18 to be licensed in small boat operation.

Boat smart from the start, take a boating safety course and get a free vessel safety check annually for your boat. For more information, contact: United States Coast Guard Auxiliary, www.cgaux.org; United States Power Squadrons, 1-888-FOR-USPS, www.usps.org.

Most boaters can enhance their enjoyment of boating experiences through increased knowledge of safe operation, navigation and regulation of pleasure boats. The following is a list of some other agencies and organizations that offer Water Safety, First Aid and CPR courses or information. To find boating safety courses in your area, call your state's local boating agency or the USCG boating safety courseline at 1-800-336-2628 (1-800-245-2628 in Virginia).



- American Red Cross
- U.S. Coast Guard Auxiliary
- U.S. Power Squadrons
- State Boating Offices
- Canadian Power and Sail Squadrons
- Boat Owners Association of the United States
- National Safe Boating Council

Operating By Minors

Minors must be supervised by an adult whenever operating a boat. Many states have laws regarding the minimum age and licensing requirements of minors. Be sure to contact the state boating authorities for information.

Overloading



WARNING

An overloaded boat can cause death or serious injury. Do not purposely overload or add any additional water to the boat other than to the Nautique Launch Control System.

DO NOT overload your boat. Your boat is equipped with a required capacity plate indicating the maximum acceptable load as determined by the manufacturer following certain Federal guidelines. If in doubt, contact your Nautique dealer.

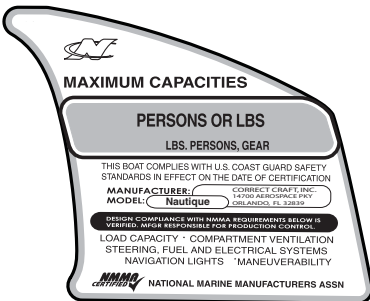

CORC201



Section I

The capacity plate is used by boat manufacturers participating in the National Marine Manufacturers Association certification program. Nautique has submitted your model for inspection and compliance with their guidelines.

The capacity plate has the following information permanently printed on it. It is attached to the boat by the throttle for the operator to read before they drive the boat.

- The total weight of persons, gear and other items which the boat is capable of carrying under normal conditions. **This weight must include any added ballast other than the Nautique Launch Control System™.**
- Death or serious injury can occur from overloading the boat. DO NOT purposely overload your Nautique boat. Do not fill the bilge area with water to act as ballast.
- The maximum number of persons allowed on the boat. This information on the capacity plate applies under normal conditions and special care must be used in any other than normal conditions. Check the capacity plate on your boat and abide by these limits.

NOTICE

Correct Craft, Inc. installs permanent wake enhancement ballast tanks called the Nautique Launch Control System™ in some models. The full weight of this system has already been considered in the boat weight and therefore does not influence maximum capacity, unlike portable ballast tanks or weights, which must be included as part of the gear weight.

An overloaded Nautique will handle differently than a lightly loaded one. Drive and turn your Nautique with this in mind. As wakeboarding has developed, we have witnessed the advent of ballast systems which add weight and increase the size of the wake. The simplest ballast system on the market is the water ballast type, such as the “phat sack.” It is not uncommon to see operators use such systems and then put additional people in their boat. Please be advised that this practice can lead to overloading your boat. Each Nautique boat has a required capacity label displaying the



maximum weight of people, gear and ballast that can be placed in the boat. Always be aware of the load in your boat and do not load the boat in excess of the listed capacity. The quest for the "phattest" wake has caused some to excessively overload their boats. Overloading the boat will affect the operation and, possibly result in injury to persons inside and/or outside of the boat.

Passenger Safety and Seating

Make sure that at least one passenger is familiar with the operation and safety aspects of the boat in case of an emergency. Show all passengers the location of emergency equipment and explain how to use it.

The operator of the boat is responsible for the safety of the passengers as well as his/her own safety. The operator should ensure that all passengers are properly and securely seated in appropriate seating locations before starting.

While the engine is running, and during the boat mooring, all occupants should be properly seated. **DO NOT** sit on the engine box, seat backs, boarding platform or gunnels. You could fall overboard and be hit by the propeller. **DO NOT** allow objects, arms or legs, or any other body parts to hang over the bow or gunnels.

DO NOT stand while the boat is moving.

The operator **MUST** sit in the driver's seat while the boat is moving and all passengers remain properly seated.

Visibility



WARNING

Obstructed visibility can cause death or serious injury. Maintain clear visibility at all times. Arrange passengers and equipment for maximum visibility or designate a passenger to assist when visibility is limited.



Section I

The operator of the boat is responsible by law to “maintain a proper lookout by sight and hearing.” The operator must ensure that he/she has an unobstructed view particularly to the front. No passengers or equipment should block the operator’s view.

Look carefully before turning, especially when you are turning around to pick up a fallen skier. Someone else may not be following the “Rules of the Road.”

Keep a visual check for boats behind your boat. This is an area where accidents can happen very quickly.

The boat should not be driven at a rate of speed faster than will allow it to be brought to a full stop within the operator’s field of view.

Boating Under the Influence



WARNING

Impaired operation can cause death or serious injury. Federal and state law prohibit operating a boat under the influence of alcohol and other drugs. These regulations are actively enforced.

Boating, alcohol and the use of other drugs just do not mix. Mixing boating, alcohol and other drugs result in many marine accidents and deaths. These substances decrease your reaction time and impair your judgment. Combined with the sun, wind, waves and noise of other watercraft, the effects of drugs are increased and will significantly increase your reaction time. As the owner/operator, you are responsible for the alcohol/drug use and on-board behavior of your passengers.

NOTICE

If the operator’s blood alcohol content is above the legal limit, violators are subject to a civil penalty up to \$1,000.00 or criminal penalty up to \$5,000.00, one year imprisonment or both. Operating a boat under the influence can also result in a loss of automobile driving privileges.



Reporting Accidents

The USCG requires the owner or operator of a boat involved in an accident, to report the incident to the proper marine law enforcement agency for the state in which the accident occurred. Immediate notification to the nearest State boating authority is required if a person dies or disappears as a result of a recreational boating accident. If a person dies or sustains injuries requiring more than first aid, a formal report must be filed within 48 hours of the accident. A formal report must be filed within 10 days for accidents exceeding \$500 in property damage or complete loss of boat.

Rendering Assistance

If you see a distress signal or suspect a boat is in trouble, you must assume it is a real emergency and render assistance immediately. By law, the operator in charge of the craft is obligated to provide assistance to any individual in danger if such assistance can be provided safely. Failure to render assistance can result in a fine and/or imprisonment.

The 1971 Boating Safety Act grants protection to a “Good Samaritan” boater providing good faith assistance, and absolves a boater from any civil liability arising from such assistance.

Required Safety Equipment

The Federal Boat Safety Act of 1971 (FBSA/71) established minimum safety standards for boats and associated equipment, specified by the USCG. In addition, the ABYC and the NMMA work with boat builders to develop voluntary standards that exceed base requirements.

The included safety equipment on your Nautique boat meets or exceeds the standards of the USCG, ABYC and the NMMA. Some required safety equipment such as PFDs are not included with your Nautique boat. Your Nautique dealer can help you choose the appropriate equipment.

NOTICE

*Many states' equipment requirements go beyond USCG requirements.
Contact your state boating office for further information.*



Section I

Equipment requirements for coastal and inland waters differ. Check with local authorities or the USCG for further information about coastal water requirements.

The following equipment may or may not be required by federal/local regulations.

Life Saving Equipment

Federal law requires at least one Type I, II, III, or V Personal Flotation Device (PFD), of the proper size, for each person on-board or being towed, and at least one Type IV throwable PFD in the boat.

There are four types of PFDs to wear and one type used for throwing in emergency situations.

Type I Life Preserver: Most buoyant PFDs are effective on all waters, especially open, rough water.

Type II Buoyant Vest: Good for calm water near shore on most inland waters where quick rescue is likely.

Type III Flotation Aid: Good for most inland water applications where quick rescue is likely. Come in various styles and some are designed for watersport activities.

Type V Hybrid PFD: Inflatable design for special use activities and may be used instead of a Type I, II, or III PFD if used in accordance with the approval conditions on the label and if worn when the boat is underway. Some Type V PFDs provide increased protection against hypothermia.



Type I
Life Preservers

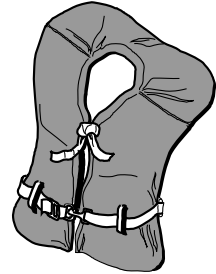

Type II
Buoyant Vests



Type III
Flotation Aids



Type V - Hybrid PFD
Must Be Worn
When Underway



NOTICE

- *A Type V PFD must be worn to be counted toward the minimum carriage requirements.*
- *Special PFDs are available for skiing and other watersports. These PFDs are constructed with materials suitable for high impact falls.*

PFDs are intended to help save lives. The operator should set an example by wearing one. Wear a PFD whenever boating. It is especially important that children and non-swimmers wear a PFD at all times. Make certain all passengers know how to put on and properly adjust their PFDs. Also, selecting the proper type PFD for your kind of outing helps ensure your time on the water can be the safest possible.

At the beginning of each season, check PFDs for damage and test for proper flotation. Refer to the PFD manufacturer's information.

All boats over 16 feet (4.8 meters) in length must carry one USCG approved Type IV throwable lifesaving device, such as a ring buoy or buoyant cushion. To meet requirements, each lifesaving device must have a current, legible USCG approval stamp permanently affixed.

Type IV Throwable Device: Intended for heavy traffic inland waters where help is available. Designed to be thrown to a person in the water and should never be worn.

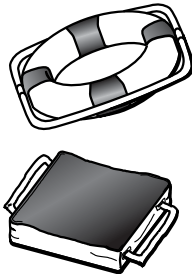

**Type IV
Throwable Devices**

Your Nautique dealer can help you select appropriate PFDs and throwable lifesaving devices for your area.



Section I

Navigation Lights

All power boats underway between sunset and sunrise must display proper navigation lights. All boats at anchor must display a proper anchor light. The anchor light must be visible 360 degrees.

Horn or Whistle

All boats over 16 feet (4.8 meters) in length must be equipped with an operable horn or whistle, audible from one mile. Your Nautique boat is equipped with a USCG-approved horn.

Fire Extinguisher

At least one approved B-1 portable fire extinguisher is required. Make sure all passengers know the location and operating procedure for each fire extinguisher. Check fire extinguisher regularly for condition and state of charge.

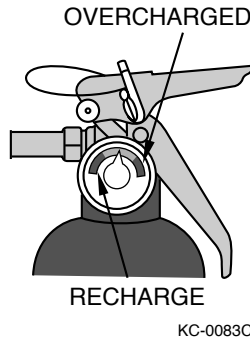

Portable Fire Extinguisher

Fire Suppression Equipment

If your Nautique is equipped with a fixed automatic fire extinguisher, it is mounted in the engine compartment. This type of extinguisher is activated when a heat-sensitive head reaches a pre-determined temperature. The extinguisher discharges to displace oxygen in the engine compartment to smother the fire. Make sure the extinguisher is charged properly before operating the boat.



WARNING

FIRE/EXPLOSION HAZARD

The gas of the fire extinguisher displaces oxygen to “smother” the fire. Oxygen feeds fire and flashback can occur, which can cause death or serious injury. If the on-board fire system discharges, **DO NOT** open the hatch, wait at least 15 minutes.

Visual Distress Signals

All boats over 16 feet (4.8 meters) must have on-board day and night visual distress signals when operating on coastal waters, the Great Lakes, territorial seas or those waters directly connected to them, up to a point where the body of water is less than two miles wide. Carry several types of signaling devices to handle a variety of conditions. Your Nautique dealer can help you select appropriate visual distress signals for your area.

If you are required to carry distress signals, you must have three USCG-approved pyrotechnic devices. Be sure they are in serviceable condition, not exceeding the expiration date and stored in a cool, dry location in a waterproof container. Have enough signals on-board to last three days.









WARNING

Pyrotechnic signaling devices can cause fire and/or explosion, death, serious injury and property damage if improperly handled. Follow the manufacturer’s directions.

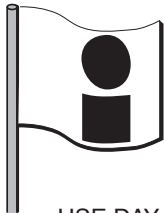

Section I

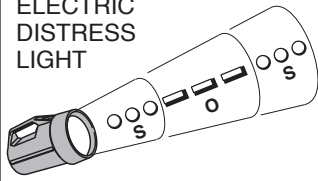
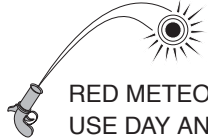
VISUAL DISTRESS SIGNALS

 <p>ORANGE FLAG</p> <p>USE DAY ONLY</p>	<p>RED DISTRESS FLARE (HAND)</p>  <p>USE DAY AND NIGHT</p>
 <p>ARMS SIGNALS (USE BRIGHT CLOTH)</p> <p>USE DAY ONLY</p>	<p>USE DAY ONLY</p>  <p>ORANGE SMOKE SIGNAL (HAND)</p>
<p>ELECTRIC DISTRESS LIGHT</p>  <p>USE NIGHT ONLY</p>	<p>RED METEOR FLARE USE DAY AND NIGHT</p>  <p>DYE MARKER USE DAY ONLY</p> 

KC-0082



Recommended Safety Equipment

As a precaution, a good boater will avoid potential problems on an outing by having additional equipment on-board. Normally, this equipment is dependent on the body of water and the length of the trip; your Nautique dealer can assist you:

- First aid kit and manual
- Anchor with at least 75 feet (23 meters) of line
- Mooring lines and fenders
- Bailing device (bucket, hand pump)
- Combination oar/boat hook
- Local charts and compass
- Day/night distress signals
- Waterproof flashlight and spare batteries
- Cellular phone
- Binoculars
- Portable AM/FM radio with weather band
- Lubricant
- Tool kit
- Spare propeller and mounting hardware
- Spare fuses
- Spare keys
- Sunglasses and sun block lotion

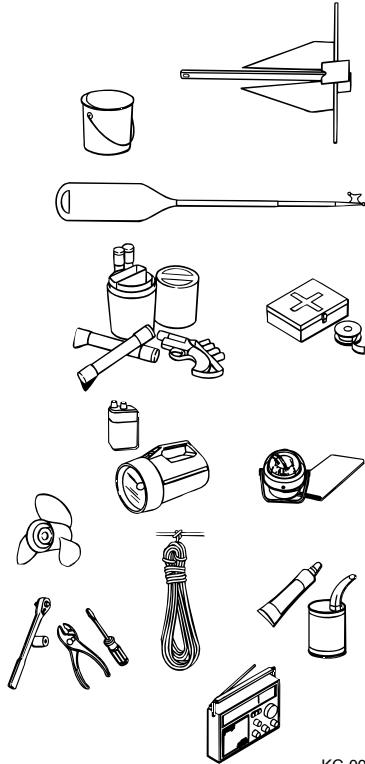

KC-0090

Emergency Stop Switch and Lanyard

Your Nautique boat is equipped with an emergency stop switch and lanyard. Nautique strongly recommends that the lanyard be secured to the operator and the lock plate attached to the emergency stop switch prior to starting the engine and anytime the engine is operating.

The lanyard is designed to turn off the engine whenever the operator moves far enough away from the helm to activate the switch. It is strongly recommended that the lanyard be used by the operator.



WARNING

An Emergency Stop Switch system that is not used or does not function properly can cause death or serious injury. DO NOT operate the boat if the Emergency Stop Switch system does not function properly.

- Attach the emergency stop switch lanyard to a secure place on your clothing, your arm or leg while operating.
- DO NOT attach the lanyard to clothing that could tear loose. DO NOT route the lanyard where it could become entangled, preventing it from functioning.
- Avoid accidentally pulling the lanyard during normal operation. Loss of engine power means loss of most steering control. Also, without engine power, the boat could slow rapidly. This could cause people and objects in the boat to be thrown forward.

There are practical limitations to what the emergency stop switch and lanyard can do. It can take several seconds for the engine and propeller to stop turning. The boat can continue to coast for several hundred feet depending on the velocity at the time the switch was activated, and the degree of any turn. While the boat is coasting, it can cause injury to anyone in its path as seriously as if the boat operated under power.



Replacement lanyards should be of sufficient length to avoid inadvertent activation. Accidental loss of power can be hazardous particularly when docking or in heavy seas, strong current or high winds.

Emergencies

Be prepared to deal with emergencies before they happen. Try to formulate a plan for each type in advance so that decisions can be made quickly and without hesitation. Precious moments lost can mean the difference between losing and saving a life.

Fire/Explosion

You must be prepared and act quickly when dealing with a fire. It is not recommended to battle a fire for an extended period of time. Turn engines off and abandon the boat if the fire cannot be extinguished quickly. Swim at least 25 yards (23 meters) upwind from the boat and use the visual distress signals to get assistance.



WARNING

Burn hazard from gasoline floating on water which is ignited can cause death or serious injury. Gasoline will float on top of water and can burn. If the boat is abandoned, swim upwind, far enough to avoid fuel that can spread over the surface of the water.

On-board fires involving the fuel system usually result in either an explosion that completely destroys the boat, or the boat burning to the waterline and self-extinguishing. Deciding on abandoning the boat or staying to fight the fire is difficult and depends on many factors. Try to formulate a fire plan in advance to help make that decision quickly and without hesitation.

Be sure to:

- Use caution and do not smoke when refueling.
- Verify that fuel does not leak.
- Use only marine-approved equipment on your boat.



Section I

Capsizing and Swamping

A boat may capsize or swamp when least expected. Like fires, try to formulate a plan in advance on what to do if it should happen. Keep in mind the following guidelines:

- Try to turn the engine off to prevent damage.
- If others were on-board, try to locate them, make sure they are conscious and that they can swim.
- **Stay with the boat, it will float!** Climb up on the hull and try to get assistance.
- Do not try to swim to shore. It is usually farther than it looks.

If a leak is discovered, immediately determine the cause. A collision with an underwater object could cause the hull to develop a leak. A loose fitting or hose clamp on a piece of equipment could cause a leak. Try to repair the leak if possible. If a leak is threatening the safety of you and your passengers, call or signal for assistance.

Collisions

If a collision occurs, immediately account for all passengers. Assess the hull for damage and activate the bilge pumps to reduce any water intake. Try to operate the boat to keep the damaged area above water. If necessary, call or signal for assistance.

Grounding

In the event you run aground, assess the situation before proceeding. Immediately stop any water from entering the boat. Inspect the rudder and rudder control system, the hull, propeller and strut for damage. Maneuver the boat to safe water only if the hull and all operating systems are in satisfactory operating condition. Otherwise, call or signal for assistance.

Water Rescue (Man Overboard)

Immediately react to a person who has fallen overboard. Keep the victim constantly in your sight. Safely return to the victim as soon as possible. Throw the person a life preserver. Turn off the engine and help the person into the boat.



Medical Emergency

Be prepared in the event of an emergency. Know how to use your first aid kit. Be aware of any special medical conditions of your passengers.

Operation Failure

If you experience a propulsion, steering or control failure, immediately turn off the engine. Try to determine the failure and repair, if possible. Otherwise, call or signal for assistance.

Hazardous Conditions

Every waterway poses hazards that you should avoid, such as shallow water, tree stumps and sand bars. Ask local boaters for information and consult a marine chart when boating on unfamiliar waters. As the operator of the boat, you should try to avoid all hazards, known and unknown. The following information does not contain all possible water hazards.

Shallow Water Operation

Operating in shallow water presents a number of hazards. If a vibration is noticed after striking an object, it may indicate a damaged propeller shaft or propeller.

Sand bars in narrow inlets are constantly shifting, making it difficult to mark them with buoys. Tides in coastal areas affect water levels producing sand bars. Sometimes sand bars are indicated by waves as they form into breakers when passing over the sand bar. Refer to Grounding, in this section, if you run aground on a sand bar.

Weeds

Weeds are generally a threat to your boat's engine. Weeds on the propeller may cause a vibration. They may also restrict water intake causing the engine to overheat. If you run into weeds, stop the engine and clear the propeller and water intakes completely of weeds. Refer to your engine Operator's Manual for additional information.



Section I

NOTICE

Weeds can sometimes be removed by shifting to NEUTRAL, pausing for a moment, then shifting to REVERSE to unwind the weeds from the propeller.

Dam Spillways

The water level around a dam spillway is a hazardous area. It is subject to rapid changes caused by currents and turbulence. Keep clear of the spillway areas below dams.

Weather/Seas

Getting caught in severe weather is hazardous. It is recommended to check the weather, sea and wind conditions not only before, but also periodically while you are boating.

A change in wave height, wind direction and speed indicates deteriorating weather. Take common sense precautions if you are forced to operate your boat in stormy conditions:

- Wear PFDs.
- Reduce speed and head for a safe place that you can easily reach.
- If you lose power, keep the boat headed into the waves by using the anchor.

It is best to avoid operating your boat in foggy weather. When fog sets in take bearings and log courses and speeds. You are required to emit a five-second blast from your horn or whistle once every minute. Additionally, have passengers wear PFDs and observe for oncoming watercrafts.



Warning Markers

DIVERS FLAG

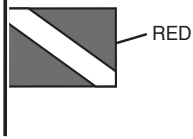

USED BY
RECREATIONAL
DIVERS -
INDICATES
DIVER'S
POSITION

ALPHA FLAG

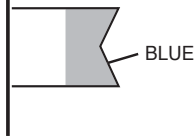

WORLDWIDE VESSELS
ENGAGED IN DIVING
OPERATIONS - DOES
NOT INDICATE
DIVER'S POSITION

DISTRESS FLAG

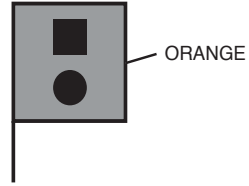

INDICATES
FELLOW
BOATER IS IN
NEED OF
ASSISTANCE

KC-0352C-a

Warning Markers

It is a good idea to ask local authorities if there are hazardous areas and how they are marked. Boaters must also recognize the flag designs, which indicate that skin divers are present and keep well clear of the area.

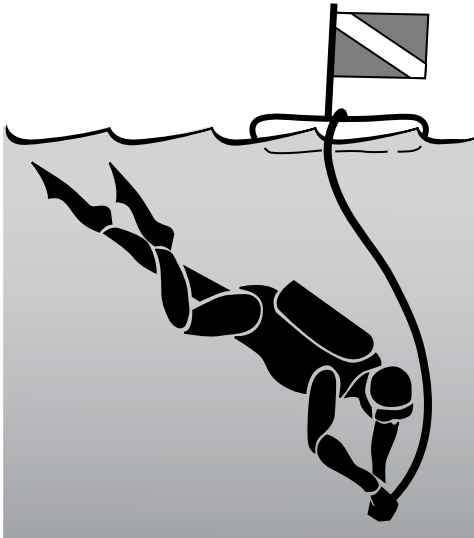

KC-0250C

Skin Diver Warning Flag

Watch for swimmers. Swimming areas may not be marked. Steer clear from the area and remain alert.





KC-0260C

Swim Area Warning Buoy

Navigation markers serve as a means of identifying navigable routes, and indicate water hazards. Boaters should become familiar with navigation markers and stay within marked boundaries and clear of hazards.

Carbon Monoxide



Carbon Monoxide (CO) is a colorless and odorless gas produced by all engines and fuel-burning appliances. Even with the best boat design and construction, plus the utmost care in inspection, operation and maintenance, hazardous levels of CO may still be present in occupied spaces under certain conditions.



Exposure to carbon monoxide (CO) can cause death or serious injury. Gasoline engines produce carbon monoxide (CO). CO is colorless, odorless and dangerous.

Direct and prolonged exposure to CO will cause brain damage or death. Signs of exposure to CO include nausea, dizziness and drowsiness. Avoid exposure to yourself and/or your passengers to carbon monoxide.

Have a suspected CO victim deeply breathe fresh air and immediately seek medical attention.

Our Environment

As a boater, you already appreciate nature's beauty and the peace of the great outdoors. It is a boater's responsibility to protect the natural environment by keeping waterways clean.

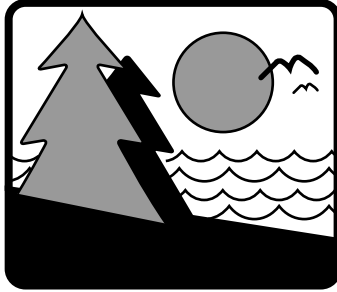

Foreign Species

If you trailer your boat from lake to lake, you may unknowingly introduce a foreign aquatic species from one lake to the next. Thoroughly clean the boat and trailer below the water line, remove all weeds and algae, and drain the bilge and ballast tanks before launching the boat in a new body of water.

Fuel/Oil Spillage



WARNING

Fire or explosion hazard from fumes accumulating from rags being stored in bilge area. DO NOT store rags used to wipe up fuel or solvent spills in the boat. Dispose of rags properly ashore.

The spilling of fuel or oil into our waterways contaminates the environment and is dangerous to wildlife. DO NOT discharge or dispose of fuel, oil or other chemicals into the water; it is prohibited and you can be fined. These are three common, accidental types of discharge:

- During initial fueling of a nearly empty tank
- Overfilling the fuel tanks
- Pumping contaminated bilge water



Section I

If the fuel tank is near empty, start fueling the tank very slowly to prevent accidental discharge. Once several gallons have been added, the fueling rate can be increased to normal.

Avoid overfilling of the tank by monitoring the fuel level gauge while fueling. Turn on the ignition without starting the engine and monitor the gauge. Stop fueling as the gauge approaches the 'full' level and turn off the ignition when finished.

Discharge/Disposal of Waste

Waste means all forms of garbage, plastics, recyclables, food, wood, detergents, sewage and even fish parts in certain waters – in short, nearly everything. We recommend you bring back everything you take out with you for proper disposal ashore.

Excessive Noise

Noise means engine noise, radio noise or even voices. Many bodies of water have adopted noise limits. Music and loud conversation can carry a considerable distance on water, especially at night. Be sure to follow regulations and be courteous.

Wake/Wash

Be alert for NO WAKE zones. Prior to entering a no wake zone, come off plane to the slowest steerable speed. Use caution when operating around smaller crafts, in channels and marinas, and in congested areas.

Exhaust Emissions

Increased exhaust (hydrocarbon) emissions pollute our water and air. Keep your engine tuned and boat hull clean for peak performance. See your Nautique dealer for information.

Paints

If your boat is kept in water where marine growth is a problem, the use of anti-fouling paint may reduce the growth rate. Be aware of environmental regulations that may govern your paint choice. Contact your local boating authorities for information.



Cleaning Agents

Household cleaners should be used sparingly and not discharged into waterways. DO NOT mix cleaners and be sure to use plenty of ventilation in enclosed areas. DO NOT use products which contain phosphates, chlorine, solvents, non-biodegradable or petroleum-based products. Citrus-based cleaners are excellent for marine cleaning purposes and are safe for you and the environment.

MARPOL Treaty

The USCG enforces the International Convention for the Prevention of Pollution from ships, commonly referred to as the MARPOL Treaty (MARine POLLution). This treaty prohibits the overboard dumping of all ship-generated plastics, chemicals, garbage and oil.

Watersport Safety

Skiers or riders are obligated to be aware of the same fundamental safety rules as operators. If you are new to water skiing, seek certified training before starting. You will find it especially helpful to join a local ski club, World Wakeboard Association and/or the USA Water Ski, when possible.

Always remember that the majority of water skiing injuries are the result of impacts with other objects. Always look where you are going and be aware of what is going on around you.

Teak/Drag Surfing

READ, UNDERSTAND and be FAMILIAR with the information contained on warning labels and adhere to the boat operation practices described on them. The United States Coast Guard issued a SAFETY ALERT on August 28, 2001 that covers some of the issues of improper use of the boarding platform. The SAFETY ALERT and portions of the accompanying information follow:



Section I

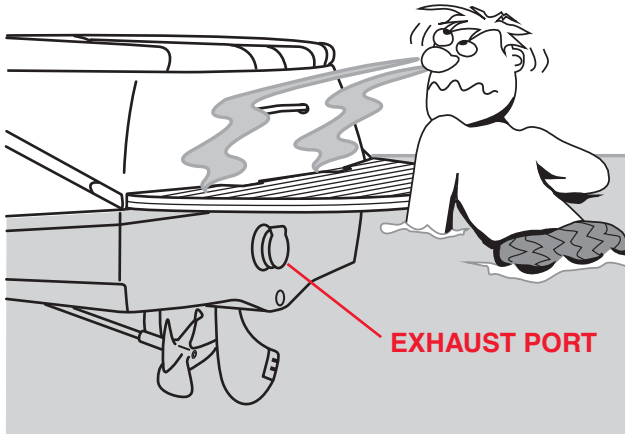

CORC023

Every year tragic deaths occur from the negligence of unsafe boating and dangerous activities. Experts say, “many of these deaths may have been caused by an invisible hazard, carbon monoxide poisoning.” Teak surfing, dragging or any other activity that exposes individuals to engine exhaust fumes which contain carbon monoxide may result in injury or death. **DO NOT** do these activities and **DO NOT** approach the back of the boat while the engine is running. Be sure to check your local and state boating laws regarding specific regulations in your area.

Nautique is concerned for all boaters’ safety and **DOES NOT** promote unsafe boating risks or jeopardizing any boaters’ safety. **DO NOT** use the boarding platform for any other purpose than boarding the boat or preparation of entering the water, and **DO NOT** use the boarding platform when the engine is running.

SAFETY ALERT From August 28, 2001:

The United States Coast Guard advised boaters not to “Teak/Drag Surf.” Recent boating fatalities revealed that carbon monoxide (CO) emitted from a vessel’s exhaust resulted in CO poisoning and the death of at least six teak surfers. “Teak/Drag Surfing” places the individual in position directly exposed to the CO in the engine’s exhaust. This may result in a loss of coherent responses and even death. In addition, “Teak/Drag Surfing” dangerously exposes the individual to a possible propeller injury, and since it is done without a life jacket (PFD), it significantly increases the probability of drowning. Therefore, the Coast Guard stresses, “Teak/Drag Surfing” is a very dangerous activity and advises boaters not to participate in it.

The Coast Guard pointed out that carbon monoxide is one of the most dangerous gases. It strikes before you know you are exposed and it impairs in a way that can and too often does lead to death. That is why it is so important to the Coast Guard that in every circumstance where it can be avoided, it is.

General Watersport Precautions

- **DO NOT ski or ride in shallow water, close to shore or in water where you do not know the depth or what is beneath the surface.**
- **DO NOT put your arm, head or any other part of your body through the handle-bridle of the ski line nor wrap the line around any part of the body at any time.**
- **DO NOT ski or ride at night or directly in front of other boats.**
- **DO NOT jump from a boat that is moving at any speed, nor enter or exit the water when the engine is running (RUN).**
- **DO NOT approach the boat if the engine is running.**
- **DO NOT ski or ride near swimming areas, beaches or personal watercraft.**
- **DO NOT follow directly behind another boat or skier without leaving an adequate safe distance.**
- **DO NOT “back up” to anyone in the water.**
- **DO NOT ski or ride with multiple skiers or riders with different length ropes.**



Section I

- **DO NOT ski or ride in limited visibility conditions.**
- **DO NOT approach the rear of the boat while the engine is running.**
- **DO NOT Kitefly.**
- **Make sure that everyone knows and uses approved skiing hand signals and common skiing courtesy.**
- **Be sure to turn off the engine before allowing anyone to approach the boat.**
- **The engine MUST be shut down (OFF) before a skier or rider enters or exits the boat, boarding platform or ladder.**
- **Every skier or rider MUST always wear a USCG-approved Type III personal flotation device. Special PFDs are available for high-impact falls into the water.**
- **Maintain a distance of at least 100 feet from all other objects, including other boats, piers, rafts, mooring and navigational buoys, pilings, abutments or any other items.**
- **Be sure to have an experienced operator and observer in the boat when skiing or riding.**
- **Look before you turn the boat to pick up a fallen skier or rider.**
- **Have ship to shore communication devices if operating at a significant distance off shore.**
- **The operator should never retrieve or pick up an article from the water while the engine is running. The engine MUST be shut OFF.**
- **The operator should always keep the skier or rider in view when the skier or rider is entering or exiting the boat.**
- **Communicate skiing or riding speed with the skier or rider before starting.**
- **The operator should know the ability level of the skier or rider.**
- **The skier or rider should indicate he/she is clear of the boat prior to starting the boat or putting the boat into gear and tightening the rope.**
- **The operator, observer, and skier or rider should agree to communication hand signals before starting.**
- **Observer in the boat should keep operator apprised of skier or rider status.**



Boating Safety

- The operator should always watch the skier or rider as the line is tightened to start (in case rope wraps around ski or skier).
- The operator should look ahead before starting.
- Start from a safe place with good forward and peripheral visibility.
- The operator should check direction of the rudder before starting (in gear, slowly making sure the boat goes straight).
- The operator should be primarily aware of what is occurring in front of the boat, but be aware of skier's or rider's progress.
- Be sure to inspect the tow eye or pylon before use. If there is any evidence of corrosion or other damage, do not use until it has been inspected by your Nautique dealer.
- Be sure to wear wet suits or protective shorts when skiing or riding to prevent abrasions, hypothermia and injuries to orifices (rectal and vaginal) from impact with a water surface.
- When people are getting on or off of watersports equipment, always turn the engine off. If boarding watersports equipment from the boat, always do so from the boarding platform.
- Always inspect watersports equipment for wear, fraying, etc., before use. **DO NOT** use if they show signs of wear or fraying.
- When approaching a skier or rider, always turn the engine off before allowing the skier or rider to come on-board. This will keep a propeller that is rotating under engine power from injuring the skier or rider.
- Be sure to approach a downed skier or rider on the operator's side; keep the skier or rider always in view.
- Display a skier down flag whenever the skier or rider is in the water and not skiing or riding.
- Inspect towline for fraying, unnecessary knots or cuts. Replace when the rope shows signs of wear. **DO NOT** wait for the rope to break before replacing an old rope.
- Be sure to follow the approved towing pattern on each lake.



Section I

When participating in watersports, be safe and courteous and follow these guidelines:

- Be considerate to fishermen and others you share the water with.
- DO NOT perform watersports in congested areas.
- Stay away from navigation markers.
- Stay away from other boats and watersports participants.

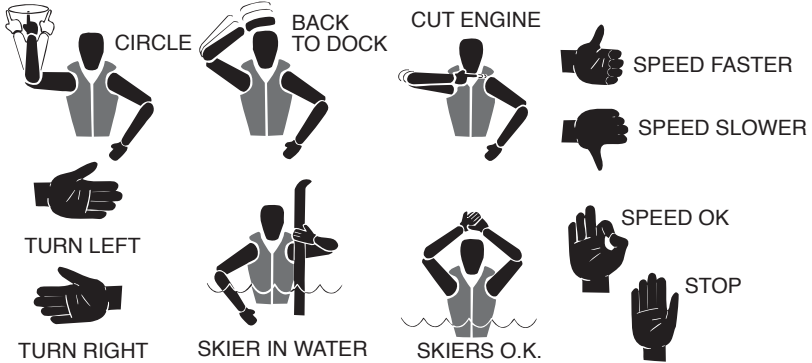

KC-0271C-a

Watersports Hand Signals

Watersports Responsibility Code

Be aware that there are elements of risk in boating, skiing and riding that common sense and personal awareness can help reduce. Know your ability level and stay within it.



Boating Safety

To increase your enjoyment of the sport follow the “Watersports Responsibility Code.”

It is your responsibility to:

- Familiarize yourself with all applicable laws, the risks inherent in the sport and the proper use of equipment.
- Know the waterways where you will be skiing or riding.
- DO NOT ski or ride in shallow water, near shore, docks, pilings, swimmers or other watercraft.
- Always have a person other than the boat driver as an observer and agree on hand signals before starting.
- Always wear a U.S. Coast Guard type III (PFD) vest.
- Read your owner’s manual and inspect your equipment prior to use.
- Ski or ride within your limits.
- Always ski or ride in control and at speeds appropriate for your ability.
- Always turn ignition off when anyone is near watercraft power drive unit.
- Avoid CO poisoning!
- Never drag within 20 feet (6.1 m) behind a moving watercraft.
- DO NOT operate watercraft, ski or ride under the influence of alcohol or drugs.



NOTES





Section 2

Basic Rules of the Road



WARNING

Hazard from collisions between boats can cause death or serious injury. Follow the nautical “Rules of the Road.”

The operator is legally required to follow the rules. The following information outlines only the most basic of the nautical “Rules of the Road.” For more information, contact your local USCG Auxiliary.

Aids To Navigation

Learn to recognize the different buoys and day markers; they are the signposts of the waterways. There are two primary marking systems in use in the U.S.: the Uniform State Waterway Marking System (USWMS), used on inland waters and maintained by each state, and the Federal Waterway Marking System (FWMS), used on coastal waters and rivers and maintained by the USCG. In addition, the FWMS has two modified systems: the Western River Buoyage, and the Intercoastal Waterway Buoyage. Be sure to check with local authorities on the buoyage system in use.

The type of hazard/warning buoys and markers depends on the area of jurisdiction. Check with local boating authorities.

The only buoys you are permitted to moor to are mooring buoys. Mooring to a navigation buoy or other navigational aid or regulatory marker is illegal.

Section 2

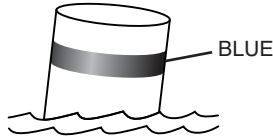

KC-0412C

Mooring Buoy – White with Blue Band May Show White Reflector or Light

USWMS System

In the USWMS Lateral System, well-defined channels are marked with red and black buoys. Lateral means the sides of the channel are marked and the boat should pass between them.

The USWMS Cardinal System is used when there is no well-defined channel or where an obstruction may be approached from more than one direction. With the cardinal system:

- Pass north or east of **BLACK-TOPPED WHITE** buoy.
- Pass south or west of **RED-TOPPED WHITE** buoy.
- **RED and WHITE VERTICALLY STRIPED** buoy indicates boat should pass outside of the buoy (away from shore).



Basic Rules of the Road

Uniform State Regulatory Markers

USWMS regulatory markers are white with international orange geometric shapes; you must obey regulatory markers.

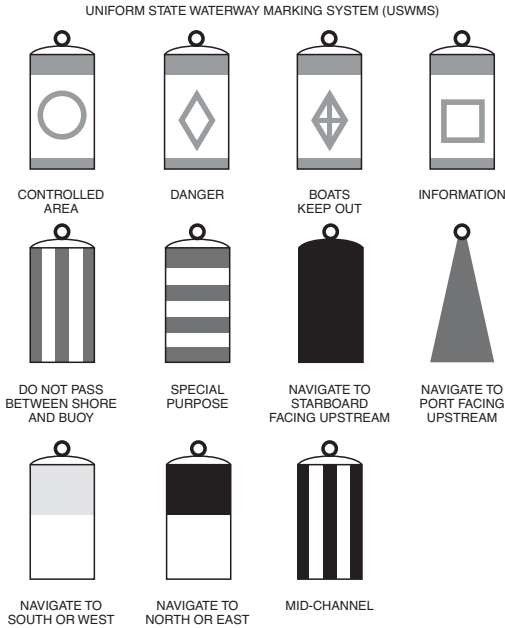

KC-0411C

Uniform State Waterway Marking System (USWMS)

FWMS System

The FWMS Lateral System is for use on navigable waters except Western Rivers and Intercoastal Waterways.

The markings on these buoys are oriented from the perspective of being entered from seaward (the boater is going toward the port). This means that red buoys are passed on the starboard (right) side of the vessel when proceeding from open water into port, and green buoys to the port (left) side.

The right side (starboard) of the channel is marked with RED, even numbered buoys. The left (port) side of the channel is marked with GREEN, odd numbered buoys.



Section 2



UNLIGHTED
BELL BUOY



SPAR BUOY



CAN BUOY



LIGHTED BUOY



NUN BUOY

KC-0420

FWMS Marking System

The middle of the channel is marked with RED and WHITE vertically striped buoys; pass close to these buoys.



KC-0430

Spherical Safe Water Marker

Obstructions, channel junctions, etc. are marked with RED and GREEN horizontally striped buoys.

A RED band at the top means the preferred channel is to the left of the buoy; a GREEN top band means the preferred channel is to the right of the buoy.

Day markers are colored and numbered the same as buoys. RED, triangular day markers with even numbers mark the starboard side of the channel. GREEN, square day markers with odd numbers mark the port side of the channel.



Basic Rules of the Road

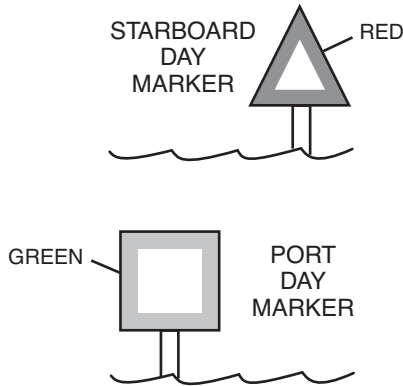

KC-0440C

Lights, bells and horns are used on buoys for night or poor visibility conditions. Buoys with unique light flashing characteristics are identified on nautical charts with the specific flashing pattern.

Right of Way

NOTICE

In general, boats with less maneuverability have right of way over more agile crafts. You must stay clear of the vessel with right of way and pass to his stern.

Privileged Boats

Privileged boats have right of way and can hold course and speed. Sailboats and boats paddled or rowed have the right of way over motor boats. Sailboats under power are considered motorboats. Small pleasure craft must yield to large commercial boats in narrow channels.

Burdened Boats

The burdened boat is the boat that must make whatever adjustment to course and speed necessary to keep out of the way of the privileged boat.



Section 2

Crossing Situation

In crossing situations, the boat to the right from the 12 o'clock to the 4 o'clock position has the right of way. It must hold course and speed. The burdened boat keeps clear and passes behind the privileged boat. Boats going up and down a river have the privilege over boats crossing the river.

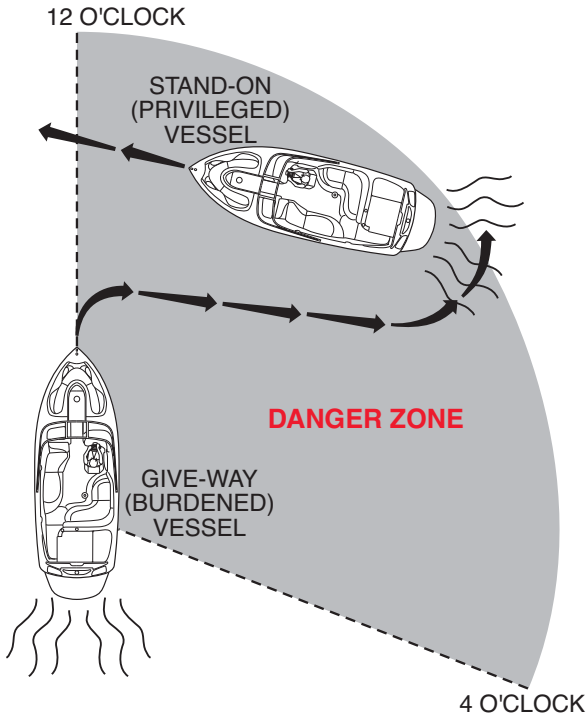

CORC017

Crossing



Basic Rules of the Road

Meeting Head-On

Neither boat has the right of way in this situation. Both boats should decrease speed, turn to the right and pass port-to-port. However, if both boats are on the left side of the channel, each vessel should sound two short blasts and pass starboard-to-starboard.

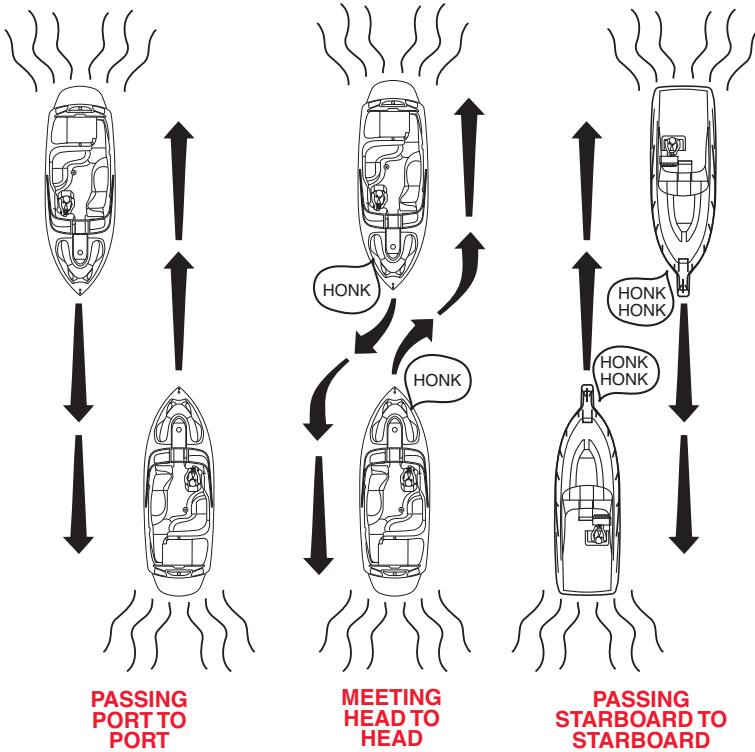

CORC018

Meeting Head-On



Section 2

Overtaking

The boat that is overtaking one ahead of it is the give-way boat and must make any adjustments necessary to keep out of the way of the stand-on boat. The stand-on boat should hold its course and speed.

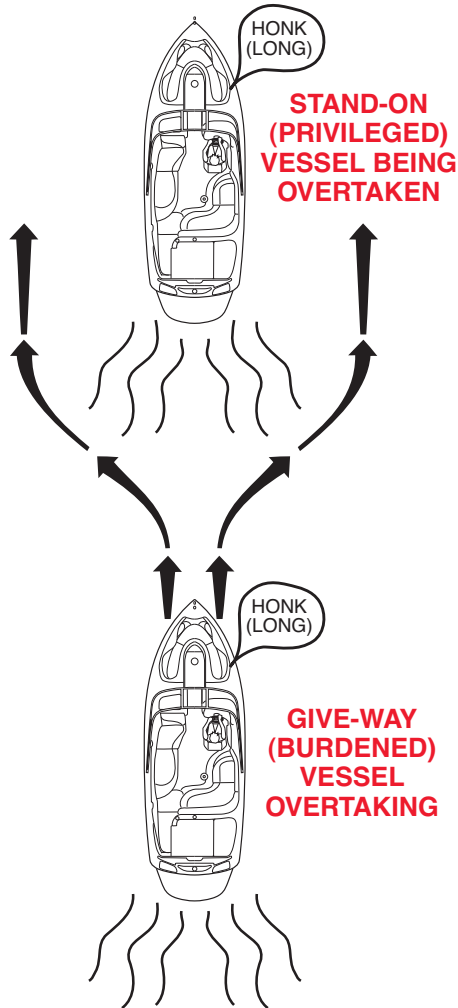

CORC019

Overtaking



Basic Rules of the Road

The General Prudential Rule

The General Prudential Rule regarding right of way, is that if a collision appears unavoidable, neither boat has right of way. As prescribed in the “Rules of the Road,” both boats must act to avoid collision.

Night Running

Boats operating between sunset and sunrise (hours vary by state) must use navigational lights. Nighttime operation, especially during bad weather or fog can be dangerous. All “Rules of the Road” apply at night, but it is best to slow down and stay clear of all boats, regardless of who has right of way. Protect your night vision by avoiding bright lights and have a passenger, if possible, help keep watch for other boats, water hazards and aids to navigation.



NOTES





Section 3

Crossover Nautique

216V/226

Specifications

216V

Length Overall.....	20' 11" (6.38 m)
Length with Platform.....	23' 1" (7.04 m)
Lifting Ring Spacing	19' 3" (5.87 m)
Beam.....	95" (2.41 m)
Draft.....	29" (0.74 m)
Approximate Dry Weight*.....	3,900 lbs (1,769 kg)
Fuel Capacity	46 Gallons (174.1 L)
Maximum Capacity	12 People or 1,800 lbs (816 kg)
Horsepower Range	343 to 390 (256 to 291 kw)
Gear Reduction Ratio.....	1.48:1
Maximum Factory Ballast Capacity.....	770 lbs (349 kg)

* Weights are estimates and can vary from options and equipment added.

Section 3

226

Length Overall.....	22' 7" (6.88 m)
Length with Platform.....	24' 10" (7.57 m)
Beam.....	98" (2.49 m)
Draft.....	31" (0.79 m)
Approximate Dry Weight*.....	4,100 lbs (1860 kg)
Fuel Capacity.....	56 Gallons (212.0 L)
Maximum Capacity.....	15 People or 2,150 lbs (975 kg)
Horsepower Range.....	343 to 409 (256 to 305 kw)
Gear Reduction Ratio.....	1.48:1
Maximum Factory Ballast Capacity.....	1,020 lbs (463 kg)

* Weights are estimates and can vary from options and equipment added.

NOTICE

The dash configurations used in this section may show more features than what is included in your Nautique.



Crossover Nautique 216V/226

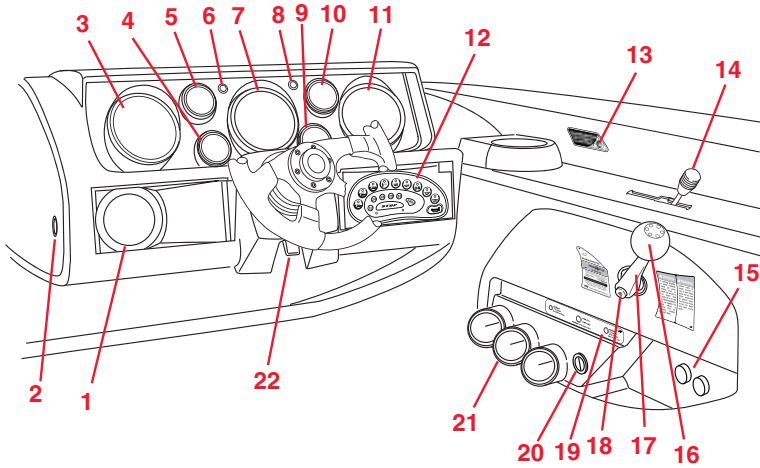

CORC208B

Dash Pod and Console

1. Digital Stereo Remote w/Clock
2. PMA Switch Panel/Breaker/Battery Switch
3. Speedometer
4. Oil
5. Fuel
6. Check Engine Light
7. Tachometer
8. Service Soon Light (catanium engine only)
9. Voltage Gauge
10. Engine Temperature Gauge
11. Nautique Cruise
12. Ignition and Switch Panel – refer to Ignition and Switch Panel in this section
13. Fire Extinguisher System – Optional
14. SportShift™ Hydro-Gate™ Control Handle
15. 12-Volt Port/Auxiliary Input
16. Shifter/Throttle Control Handle
17. Shift Safety Lock-out Umbrella
18. Neutral Warm-up Button
19. Automatic Bilge Panel
20. Emergency Stop Switch
21. Ballast Tank(s) Level Gauges
22. Steering Wheel Tilt Lever

NOTICE

A full description of the gauges and switches and their functions is discussed in Section 4.



Section 3

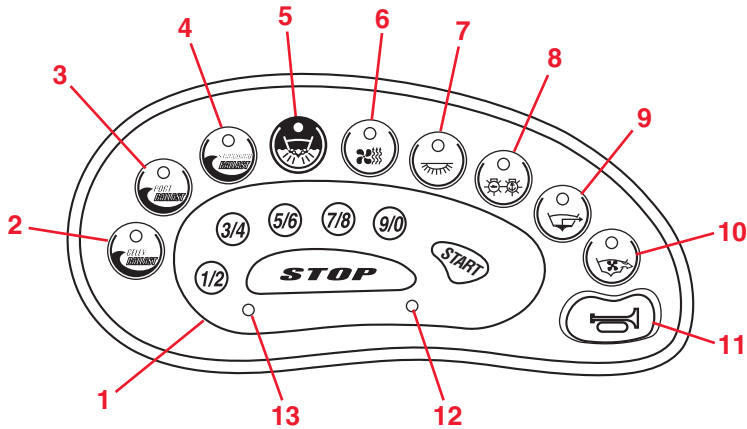

CORC083

Ignition and Switch Panel

1. Keyless Ignition Key Pad
2. Belly Ballast (if equipped)
3. Port Ballast (if equipped)
4. Starboard Ballast (if equipped)
5. Underwater Lights
6. Heater Fan
7. Courtesy Lights/Docking lights
8. Navigation Lights/Anchor Light
9. Bilge Pumps
10. Engine Compartment/Bilge Area Blower
11. Horn
12. System Indicator Light
13. Ignition Indicator Light

NOTICE

If your boat is not equipped with the features on the Ignition and Switch Panel Switch buttons, the button will not have a function. A full description of the key pad keys and switch buttons and their functions is discussed in Section 4, Dash Pod, Control Switches and Ballast Tank Control Switches.



Crossover Nautique 216V/226

Keys

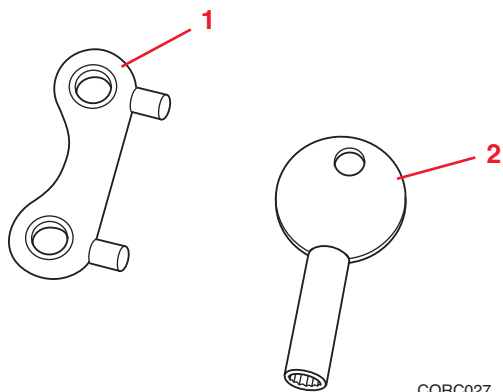

CORC027

1. Fuel Tank Fill Cap Key
2. Hatch Latch Key



Section 3

216V Deck Layout

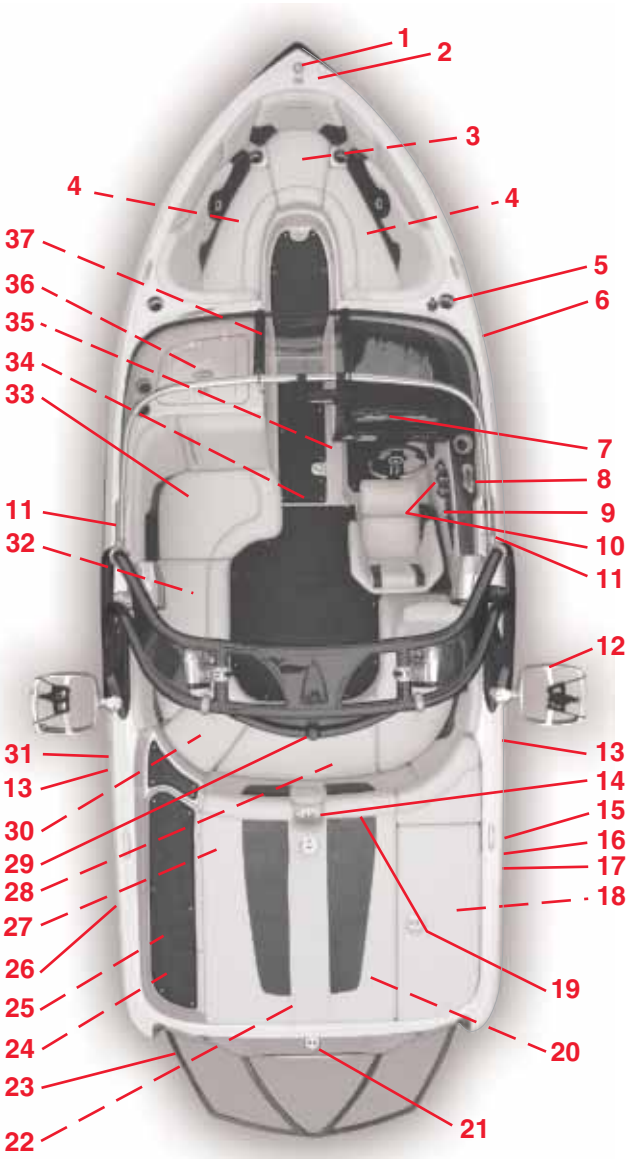

CORC0239



Crossover Nautique 216V/226

Description

1. Bow Navigation Light
2. Bow Lifting Ring
3. Anchor Storage
4. Storage
5. Cruise Control GPS Module
6. Belly Tank Vent
7. Dash Pod and Console
8. Hydro-Gate™ Control and SportShift™
9. 12-Volt Port/Auxiliary Input
10. Automatic Bilge and Ballast Tank Gauge Panel
11. Engine Compartment Air Intake
12. Tower Board Racks
13. Fuel Tank Fill
14. Watersports Tow Point
15. Forward Bilge Pump Outlet
16. Aft Bilge Pump Outlet
17. Starboard Ballast Tank Vent
18. Storage Trunk/Bilge Water Filters (European market)
19. Anchor Light Receptacle (not included with Flight Control Tower™ option)
20. Rudder Shaft Remote Lube Fitting (European market)
21. Stern Lifting Ring
22. Aft Bilge Pump/CE Fire Suppressor
23. Boarding Platform
24. Storage Trunk
25. Engine Cooling Water Intake Strainer
26. Port Ballast Tank Vent
27. Engine Flushing Adaptor
28. Built-in Cooler/T-Handle Drain/Seacock Access Seacocks (shut-off valves, ballast intake/drain, described starboard to port) Engine Cooling, Belly Ballast, Aft-Starboard Ballast, Aft-Port Ballast
29. Tower Watersports Tow Point
30. Cockpit Entrance Tread
31. Fuel Tank Vent
32. Removable Cooler
33. Observer's Seat/Storage Access
34. Forward Bilge Pump/Storage/Anchor Light Storage
35. Battery Selector Switch/PMA Panel/Breaker Panels
36. Glove Box/Stereo/Auxiliary Input/12V Port
37. Waste Basket

The primary battery is located in the port/aft storage compartment. The optional secondary battery is located in the cockpit starboard storage area.



Section 3

226 Deck Layout

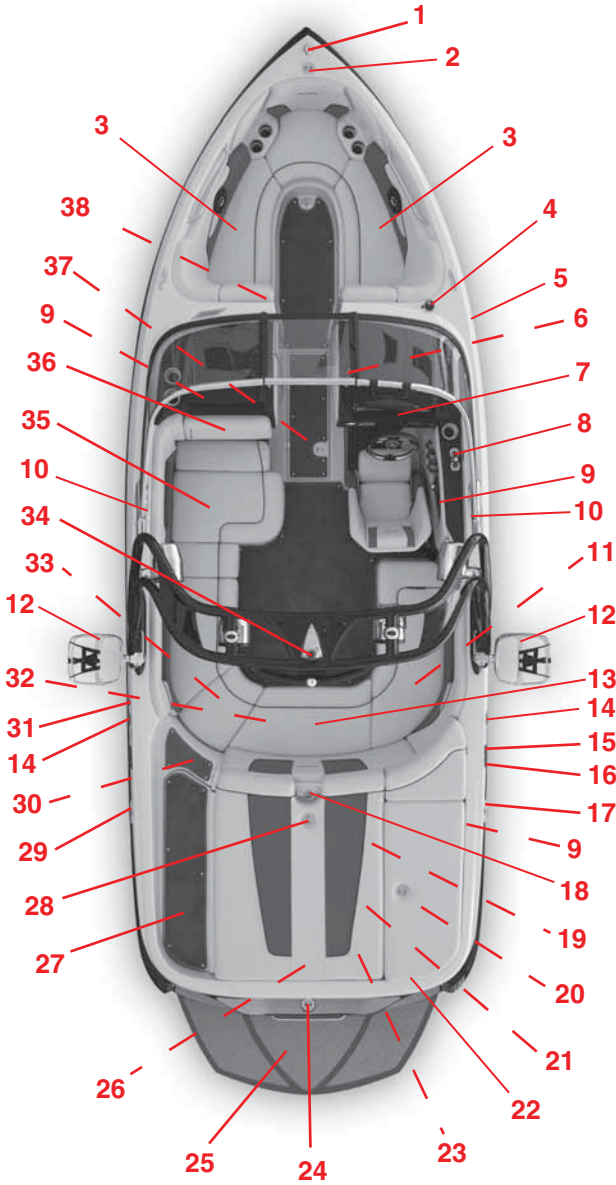

CORC0245



Crossover Nautique 216V/226

Description

1. Bow Navigation Light
2. Bow Lifting Ring
3. Storage
4. Cruise Control GPS Module
5. Belly Tank Vent
6. Battery Selector Switch/PMA Panel/Breaker Panels
7. Dash Pod and Console
8. Hydro-Gate™ Control and SportShift™
9. 12-Volt Port (3)
10. Engine Compartment Air Intake
11. Removable Cooler
12. Tower Board Racks
13. Table Mount
14. Fuel Tank Fill
15. Forward Bilge Pump Outlet
16. Aft Bilge Pump Outlet
17. Starboard Ballast Tank Vent
18. Watersports Tow Point
19. Engine Cooling Water Intake Strainer
20. Storage Trunk/Bilge Water Filters (European market)
21. CE Fire Suppressor
22. Anchor Light Receptacle (not included with Flight Control Tower™ option)
23. Rudder Shaft Remote Lube Fitting
24. Stern Lifting Ring
25. Boarding Platform
26. Aft Bilge Pump
27. Storage Trunk
28. Engine Cover Latch
29. Port Ballast Tank Vent
30. Engine Flushing Adapter
31. Fuel Tank Vent
32. Built-in Cooler/T-Handle Drain/Seacock Access (shut-off valves, ballast intake/drain)
33. Cockpit Entrance Tread
34. Tower Watersports Tow Point
35. Flip Seat
36. Port Side Dash with Glove Box, Stereo
37. Forward Bilge Pump/Storage/Anchor Light Storage
38. Waste Basket

The primary battery is located in the port/aft storage compartment. The optional secondary battery is located in the starboard/aft storage compartment.



Section 3

Standard and Optional Equipment

Nautique boats are equipped with only the finest standard and optional equipment available. Your boat's equipment will vary, based on how your boat was built. Many options can only be installed during the manufacturing of the boat and cannot be retro-fitted to boats in the field.

Not all of the standard or optional equipment's use, safety and maintenance information can be covered in this manual. You will find most of the standard and optional equipment in this manual in the section pertaining to its use and function in **Section 4**. Make sure you read and understand this manual and all the other manufacturers' literature provided in your Skipper's Kit to maximize the benefits and uses this equipment has to offer.

If you have any questions regarding the use of any equipment on your Nautique boat, contact your Nautique dealer.





Section 4

Controls and Indicators

Knowing the systems, controls and indicators on your boat is essential for safe and proper operation.



WARNING

Improperly maintained controls are hazardous and may cause sudden loss of control. Make sure all steering and shift / throttle hardware, cables and fluid levels are regularly inspected and maintained. Improper maintenance may result in a loss of control, possibly causing serious injury or death.

Steering

The steering system in your Nautique boat provides excellent maneuvering performance for pleasure boating or during watersports. Boat steering is not self-centering. Always keep a secure grip on the steering wheel to maintain full boat control. The steering wheel is equipped with a tilt lever to adjust the wheel angle to a comfortable operating position when the boat is not moving.

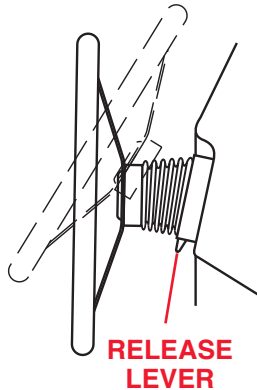

CORC133

Section 4

The helm transfers rotary motion of the steering wheel to linear motion in the cable which pushes or pulls the rudder. Nautique rudders are equipped with an adjustable trim tab under license from Z-Marine (U.S. patent 5,746,147) to compensate for the torque generated by the propeller.

Maintenance for the steering system is minimal because there are few serviceable parts. The rack and pinion for the system is lubricated and sealed during manufacturing. It is the responsibility of the owner/operator to inspect the steering system frequently.

If you experience difficulty in steering, refer to Section 8 - Care and Maintenance.



WARNING

Hazard from improper maintenance of the controls can cause death or serious injury from sudden loss of control. DO NOT operate your boat if you suspect the steering system or control are malfunctioning.

Hydro-Gate™ Control and SportShift™

The Hydro-Gate is engaged by moving the SportShift lever located at the helm's starboard side fore and disengaged by moving the lever aft. When the SportShift lever is pushed forward, the Hydro-Gate is engaged, creating maximum lift for a wake with a well-defined crest and shallower ramp. When the SportShift lever is pushed aft, the Hydro-Gate is disengaged (raised), allowing your boat to sit deeper in the water, creating the maximum wake with a steep ramp. The SportShift lever can be placed in any position to create your ultimate wake. When used in conjunction with the Launch Control System, the SportShift and the Hydro-Gate can be used to create a wide variety of wakes to meet your style and need. The SportShift and Hydro-Gate can be used at any speed or at rest.



Controls and Indicators

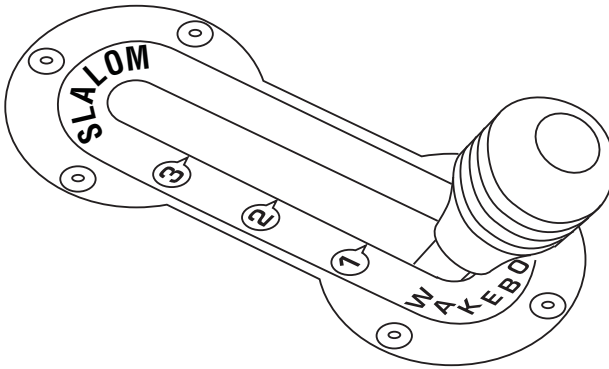

CORC142B

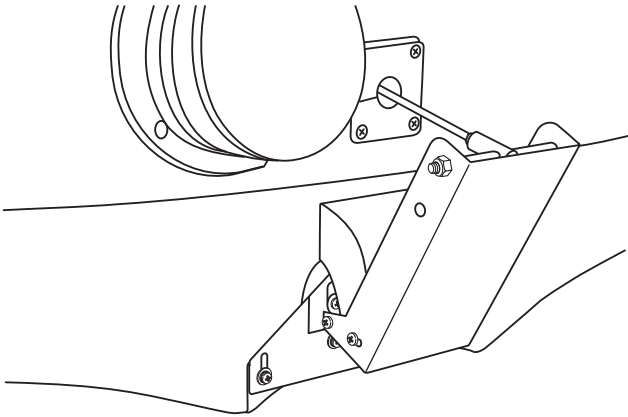

CORC143



Section 4

Shifter/Throttle



WARNING

Hazard from replacing your shift/throttle control without a start-in-gear protection system can cause death or serious injury, DO NOT replace the control with a control that does not have this feature.

Your Nautique boat is equipped with a Shifter/Throttle Control Handle which features a start-in-gear protection to prevent the boat from moving when started.

A single-lever control with neutral warm-up button and safety lock-out umbrella operates as both a gear shifter and a throttle control. When the throttle lever is vertical, it is locked in the NEUTRAL position for safety. Be sure the control is in NEUTRAL before attempting to start the engine. Lifting the safety lock-out umbrella and moving the throttle lever forward will engage FORWARD gear in the transmission and increase the engine RPM. Moving the throttle lever backward will engage REVERSE gear in the transmission and also increase the engine RPM.

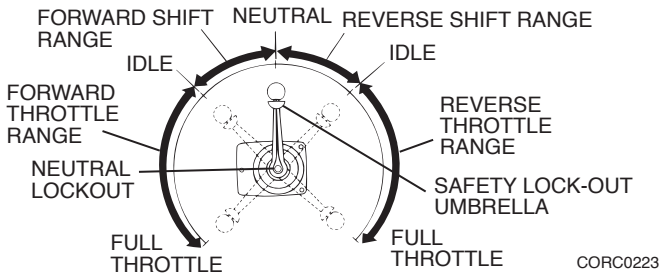

CAUTION

DO NOT shift too quickly from FORWARD to REVERSE. Stay in NEUTRAL, or idle position until the boat has lost most of its headway before completing the shift to REVERSE or engine / transmission damage may occur.



Controls and Indicators

Emergency Stop Switch

The emergency stop switch will stop the engine when the lanyard is pulled far enough to disengage it from the switch. Attach the lanyard to the boat operator whenever the engine is running but be aware there will be a loss of engine power if the switch is activated. If the operator is thrown from the seat, or moves too far from the helm, the lanyard will become disconnected from the switch, shutting off the engine. Refer to Section 1 for more information.

CAUTION

DO NOT allow your boat to be operated without the proper use of the emergency stop switch and lanyard.

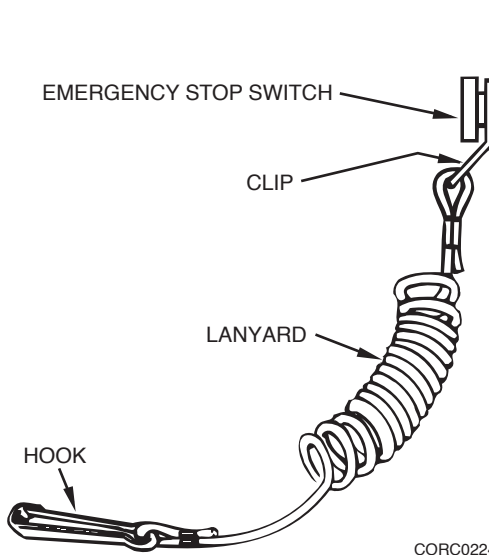

To attach a lanyard, connect the clip to the emergency stop switch and the hook to a strong piece of clothing on the operator, such as a belt loop.

NOTICE

The engine will not start unless the emergency stop switch is attached.



Section 4



WARNING

Hazard from improper use of the emergency stop switch can cause death or serious injury. The emergency stop switch is designed to stop the boat if the operator is accidentally thrown from the helm. Attach the lanyard to the operator before starting the engine.

The emergency stop switch can only be effective when it is in good working condition.

Observe the following:

- DO NOT remove or modify an emergency stop switch and/or its lanyard.
- The lanyard must be free from obstructions that could interfere with its operation.

Once a month: Check the emergency stop switch for proper operation. With the engine running, pull lanyard. If the engine does not stop, see your Nautique dealer for service of the switch.

Dash Pod Gauges

- **Volts** - Indicates the condition of the engine's cranking battery in volts DC. With the ignition switch on and the engine not running, a reading above 12.5 volts indicates a fully charged battery. With the engine running at idle, the gauge should read between 12.5 and 13 volts. With the engine running at cruising speeds and above, it should show 13 to 14.5 volts. Have your Nautique dealer check the charging system if the voltmeter reads outside these normal ranges.
- **Temp** - Indicates the engine coolant temperature. Refer to the engine manual for normal operating temperature. After starting the engine, check your temperature gauge for abnormally high readings. If the reading is outside the manufacturer's operating range, immediately turn off the engine. An abnormally high temperature indicates a cooling system problem. See your Nautique dealer when experiencing a high engine temperature reading.



Controls and Indicators

- **Oil Pressure** - Measures the pressure of the engine's lubricating oil. Refer to the engine manual for normal operating pressure. Many serious engine problems are reflected on oil pressure gauge readings. If the pressure is lower than the manufacturer's specification, immediately turn off the engine. Contact your Nautique dealer to correct the problem before operating the engine.
- **Tachometer/Hour Meter** - Registers engine speed in revolutions per minute (RPM). Use the tachometer to keep the engine within the proper operating range. Consult the engine manual for the proper RPM operating range of your engine. The hour meter LCD display registers accumulated engine operating time. Time will not be logged unless the ignition switch is on and the engine is running. Use the hour meter to keep accurate logs for scheduled maintenance.
- **Speedometer** - Your Nautique is equipped with a precision speedometer by Faria. This gauge registers forward speed in miles per hour (optional kilometers per hour). The speedometer is equipped with an adjustment knob to calibrate speedometer accuracy. You can also use this gauge to monitor fuel consumption and propeller performance.
- **Check Engine Light** - This light will turn on when the ignition is turned (engine not cranking); it will turn on for a few seconds, then turn off. The check engine light will come on for all other engine-related problems. This light will be off when the engine is running. Refer to the engine manual for additional information.
- **Service Soon Light (Catanium Engine Only)** - This light will turn on and stay on until either the engine is started or the ignition is switched off. The service soon light will come on if there is a problem with the catalyst system. This light will be off when the engine is running.



Section 4

Speedometer Calibration

The speedometer calibration control knob is located on the under side of the deck beneath the dash pod above the driver's right knee. Drive the boat at a known speed using a GPS or measured course and adjust the knob until the speedometer is reading correctly. Turning the knob one direction will raise the needle reading while turning it in the other direction will lower the reading.

12-Volt Port

This receptacle can be used to power and charge cellular phones, MP3 players, video cameras or other electronics. These receptacles are powered through a 10-amp breaker.

Ignition Keyswitch

This keyswitch starts and stops the engine. A built-in protection system prevents the engine from starting in any gear other than NEUTRAL. Refer to Shifter/Throttle in this section and consult the engine operator's manual for more information.

There is an accessory position on the ignition keyswitch and an associated terminal on the back of the switch provided to control power to add on accessories. Even though power to this terminal is protected by a 20-amp fuse, do not connect any accessory that draws more than 10 amps. Attaching an accessory to this terminal should only be done by a qualified technician.

CAUTION

The keypad and switch control box will be damaged beyond repair if the boat's battery cables, the main switch control box power leads or battery charger leads are reversed. DO NOT reverse these connections.

Control Switches

Each electrical circuit on your boat is equipped with a control switch. The switches have an indicator light for easy ON/OFF identification. All switches are fuse protected.



Controls and Indicators

Belly, Port, Starboard Ballast

These buttons fill and drain the ballast tank designated to the switch. Ballast tanks are an option on most Nautique boats. A full description of how these buttons function is discussed in **Section 4, Ballast Tank Control Switches**.

Underwater Lights

This switch controls the transom underwater lights. **DO NOT** operate lights while the boat is out of the water.

Heater Fan (if equipped)

The heater button controls four different heater functions.

Pressing and releasing the heater button turns on Low Speed.

Press again for Medium Speed.

Press again for High Speed.

Press again for Off.

The indicator light for this button will illuminate if the heater is running at any of the three speeds.

Courtesy/Docking Lights

Press and release for courtesy lights, press and hold from this position to turn docking lights on with courtesy lights. To turn the courtesy lights and the docking lights off, press and release. Docking lights only: from the OFF position, press and hold until the docking lights are on and release, to turn off, press and release.

NOTICE

If either or both of the two light functions are on, the indicator light will illuminate and a press and release will turn off any of the lights that are on.



Section 4



Engine Compartment/Bilge Area Blower

The blower switch activates the engine compartment ventilation blower to remove explosive fumes from the area. The blower is turned on or off by pressing and releasing the button. The blower must be operated for a minimum of four minutes each time before starting the engines or generator. In addition, the blower should be operated continuously when at idle or running at slow speeds.



WARNING

Explosion and fire hazard from gasoline vapors can cause death or serious injury from failure to check for fumes in the engine compartment or operating the blower. Before engine start-up, check engine compartment for gasoline vapors, then operate blower for at least four minutes. Operate blower whenever below planing speed.

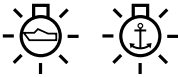

Navigation/Anchor Light

A quick press and release of this button turns on the navigation lights, and the indicator light for this button will illuminate. A press and slight hold will only turn on the anchor light and cause the indicator light to flash. A press and release of the key turns off both of the lights.



WARNING

Blocking navigation lights can cause death or serious injury. DO NOT block the navigation lights.



Controls and Indicators



Bilge Pump

The bilge switch turns on the bilge pump to remove excess water from the bottom of the boat. The pump turns on or off by pressing and releasing the button. There is a bilge pump near the rudder and one in the front. When you turn the switch on, the pump(s) will operate and run for several moments to “sense” if there is water in the bilge. If there is water in the bilge, the pump(s) remains on until the water is pumped out. If there is no water in the bilge, the pump(s) will turn off. If you want immediate pump action, turn the switch off and then back on again. The pump(s) will turn on periodically to determine if there is water in the bilge. If so, they will remain on until the water is pumped out.

The bilge switch must be turned on for this feature to operate. This will not drain significant power from the battery unless the bilge pump(s) is required to run frequently because of a leak or excessive rainwater. This pumping system should not be relied on over an extended period of time. Frequently inspect your boat for evidence of excessive water in the bilge area. See your Nautique dealer if you have any questions.

NOTICE

Trash in bilge area can damage the bilge pumps.



Horn

The horn button is a momentary switch. The horn will operate whenever the button is pressed and will stop when the button is released.



Section 4

Dash Pod

Ignition and Switch Panel



CORC137

NOTICE

Some of the switches on your boat may not have a function, based on the way the boat is equipped.

Keyless Ignition

The optional ignition switch system is keyless and has three modes of operation.

CAUTION

The keypad and switch control box will be damaged beyond repair if the boat's battery cables, the main switch control box power leads or battery charger leads are reversed. DO NOT reverse these connections.



Controls and Indicators

Locked Mode

When the boat's battery is first connected, the unit is in Locked Mode. In this mode, only the horn, bilge pump, bilge blower and code keys operate.

Unlocked Mode

Unlocked Mode is entered after the user successfully enters the user code and presses and releases the start key. When the code keys are pressed, the system indicator light will turn on while the key is pressed. This indicates the key has actually been pressed. When the system is unlocked, power is supplied to the boat and the system indicator light will turn on. At this point all keypad keys will operate and actuating these keys will control the corresponding boat functions. To put the unit back in Locked Mode, the user must successfully enter the user code, then press the STOP key. This will turn off the system indicator light and shut off power to all of the accessories except the horn, bilge pump, bilge blower and code keys.

Run Mode

Enter the Unlocked Mode.

Pressing and releasing the START key quickly will put the unit in Run Mode. Power is supplied to the engine ignition, but the engine will not crank and the ignition indicator light is turned on. If the start key is not pressed again within 15 minutes, the unit will exit Run Mode by shutting off power to the ignition and reenter the Unlocked Mode. If the user presses and holds the START key, power is supplied to the ignition and starter for as long as the user presses the START key. All accessory keys will operate in this mode. Pressing the STOP key will shut off the engine and the unit is then put back in the Unlocked Mode.

After the engine starts, release the START key.

CAUTION

DO NOT hold the START key for more than 30 seconds. The starter motor can be damaged.



Section 4

Automatic Return to Locked Mode

If no keypad activity takes place for 10 hours after unlocking, the system will automatically return to the Locked Mode to help prevent battery drain.

Automatic Back-lighting

Pressing any keypad key will automatically turn the keypad back-lighting on for 10 seconds. This feature is useful for finding the keypad at night.

Multiple Keyless Ignition Codes

The keyless ignition system has provisions for three different ignition codes. Any of the three codes may be used to unlock or lock the system.

The “Master Embedded Code” is programmed into the system at Correct Craft, Inc. It is not changeable and remains with the boat for its life. This code can be used to unlock the system, to lock the system and to erase the two user codes.

The “Primary User Code” is programmed into the system by the owner with the Nautique dealer’s help at the time of boat delivery. This code is used to unlock the system, to lock the system and to add or change the “Secondary User Code.”

The “Secondary User Code” is programmed into the system by the owner when necessary. This code is only used to unlock or lock the system. The “Secondary User Code” is ideal to limit access to the boat.

NOTICE

To help prevent battery drain, make sure you STOP the engine and LOCK the PME ignition system (two steps) when you are finished using the boat.



Controls and Indicators

NOTICE

The “System Indicator Light” is on the right side of the ignition keypad. The “Ignition Indicator Light” is on the left side of the ignition keypad.

Programming the Primary User Code

NOTICE

Until a Primary User Code is set, the keyless ignition does not require the entry of a code to unlock the system or start the engine. This system operates as follows:

1. Press START to unlock the system.
2. Press it a second time to start the engine.
3. Press STOP to turn off the engine.
4. Press it a second time to lock the system. The system indicator light should be off.

To program the Primary User Code, make sure the system indicator light is off, then press and release the 1/2 key and the 7/8 key at the same time to put the system in the Code Programming Mode. The system indicator light will flash.

Enter a code from two to eight characters and press START. For verification, reenter the code and press START again. The system indicator light should stop flashing and stay on. If the light does not stop flashing, press STOP and begin again.

To lock the system, reenter either the Primary User Code or the Master Embedded Code and press STOP.



Section 4

Changing the Primary User Code

NOTICE

The current primary code must be used to change to another primary code.

Make sure the system indicator light is off.

1. Enter the Primary User Code, then press and release the 1/2 key and the 7/8 key at the same time to put the system in the code programming mode. The system indicator light will flash.
2. Enter a code from two to eight characters and press START. For verification, reenter the code and press START again. The system indicator light should stop flashing and stay on. If the light does not stop flashing, press STOP and begin again.

To lock the system, reenter either the new Primary User Code or the Master Embedded Code and press STOP.

NOTICE

Changing the Primary User Code will erase the Secondary User Code.

Programming or Changing the Secondary User Code

NOTICE

The Secondary User Code will only lock or unlock the system and cannot be used for any reprogramming

Make sure the system indicator light is off.

1. Enter the Primary User Code and press and release the 1/2 key and the 5/6 key at the same time to put the system in Code Programming Mode. The system indicator light will flash.
2. Enter a code from two to eight characters and press START. For verification, reenter the code and press START again. The system indicator light should stop flashing and stay on. If the light does not stop flashing, press STOP and begin again.

To lock the system, reenter any of the three codes and press STOP.



Controls and Indicators

Erasing the User Codes

Make sure the system indicator light is off.

Enter the Master Embedded Code and press and release the 1/2 key and the 7/8 key at the same time to erase the system user codes.

The keyless ignition will now act as if there are no codes in memory. Pressing the START key will unlock the system and pressing the STOP key will lock it without entering a code. Follow the steps in “Programming the Primary User Code” in this section.

Nautique Cruise Control

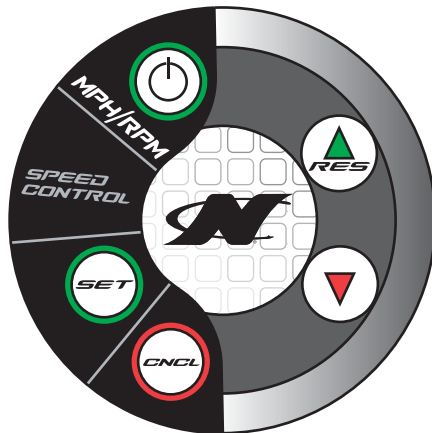

CORC219

The steering wheel hub cruise control remote has five control buttons:

⏻ (ON/OFF)

SET

CNCL (Cancel)

▲/RES (increment UP/Resume)

▼(decrement DOWN)



Section 4

There are three small lights in the dash display that indicate the status of Nautique Cruise. The top light is labeled MPH, the middle one labeled RPM and the bottom one labeled SET. When Nautique Cruise is on, either the MPH or RPM light will be illuminated and the SET light will either be off, flashing slowly or on continuously. When the SET light is off, Nautique Cruise will not control speed and the throttle control will function normally at all speeds. If the SET light is flashing, Nautique Cruise is armed but the boat speed is below the set point. The throttle control will function normally as long as the boat speed is below the set point. When the speed nears the set point, Nautique Cruise will take over controlling the speed. When Nautique Cruise takes over, the SET light illuminates continuously.

NOTICE

After Nautique Cruise takes control, it is best to push the throttle control handle down a good portion of the way toward full throttle in order for Nautique Cruise to function correctly. Nautique Cruise can be turned off by pulling the throttle back toward NEUTRAL, by pushing the Cancel button or by turning Nautique Cruise off.

When the ignition is turned off and back on, Nautique Cruise will “remember” the last set point and return to it. The indicator lights will provide the operator with an indication of the Nautique Cruise status.

There are two ways to operate the buttons on the steering wheel hub. One is to “push and release” (push and after a short delay of more than 1/2 second but less than two seconds, release the button). The other is to “push and hold” (push and after a longer delay of at least two seconds, release the button).



Controls and Indicators

Button Function

The *MPH/RPM* button turns Nautique Cruise on and off.

- When Nautique Cruise is off, a push and release of the button will turn Nautique Cruise on in “SPEED MODE,” while a push and hold will turn Nautique Cruise on in “RPM MODE.” Turning Nautique Cruise on in either mode will illuminate the appropriate light on the dash display.
- When Nautique Cruise is on, a push and release or a push and hold of the button will turn Nautique Cruise off, also turning off the dash indicator light.

The *SET* and *CNCL* buttons respond the same way to a “push and release” or a “push and hold.”

- If the *SET* light is off or flashing, the *SET* button activates Nautique Cruise at the current boat speed, causing the *SET* light to illuminate continuously while controlling the boat speed.
- If the *SET* light is on continuously, the *SET* button will have no effect.
- If the *SET* light is on continuously or flashing the *CNCL* button will turn the *SET* light off and allow the boat to be driven with the hand throttle.
- If the *SET* light is off the *SET* button will have no effect.

The ▲ (increment) and ▼ (decrement) buttons respond the same way to a “push and release” or a “push and hold” and will only function if the *SET* light is on continuously.

- The ▲ (increment) button will raise the set speed approximately 1/4 mile per hour.
- The ▼ (decrement) button will decrease the set speed approximately 1/4 mile per hour.



Section 4

Gauges

The optional dash pod uses the Faria® Serial Bus™ system which receives information from the engine ECU and various individual sensors throughout the boat. This information is transformed into digital data, which is distributed to analog and digital instruments via a single cable consisting of two shielded, twisted pairs of conductors.

Each instrument selects the data, which applies and displays it as if it was received from the sender directly. One of the two pairs of conductors carries the data while the other pair of conductors carries the power for the instruments. The tachometer and speedometer each have three push buttons, which allow the different functions of each instrument to be activated.

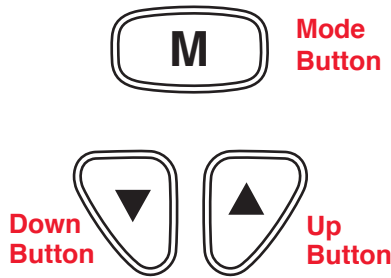

CORC113



Controls and Indicators

Refer to Standard Dash Pod in this section for additional information on gauge operation.

Speedometer/Depth Sounder

The Serial Bus Speedometer/Depth Sounder provides both the functions of a speedometer and a depth sounder. The analog speedometer looks like a standard analog device but is actually a digital instrument. On small pointer movements you may occasionally see the pointer moving in the one-third degree “steps” that represent the accuracy of the instrument.

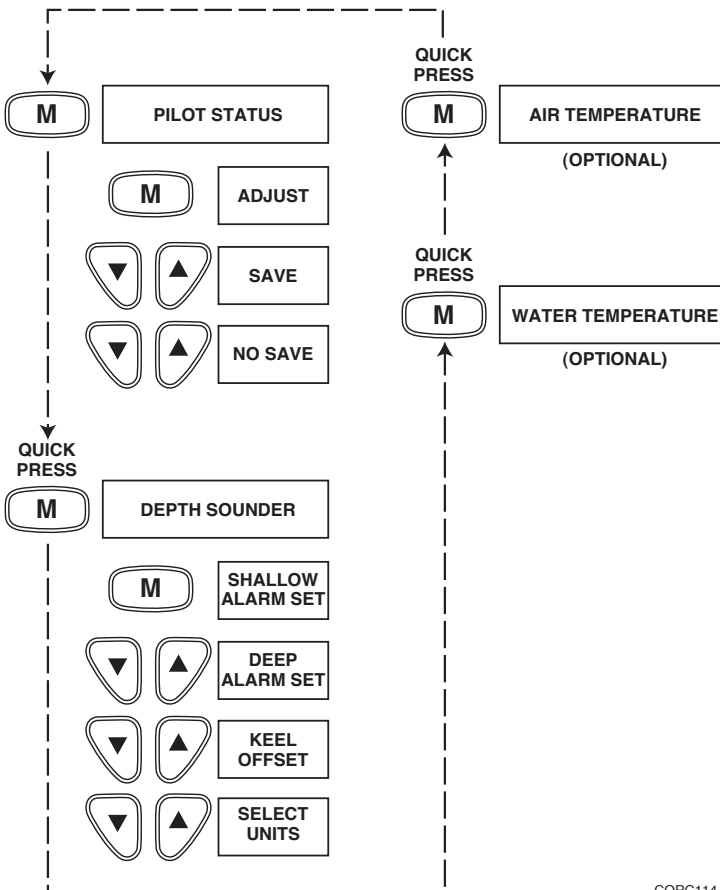

CORC114



Section 4

Speedometer Function

The speedometer measures speed over the water using a paddle wheel sensor.

Speedometer Calibration

The analog speedometer displays the speed of the boat through the water. The speedometer is calibrated at the factory; however, significant variations can occur due to changes in installations. The speedometer can be easily calibrated to a known reference such as a radar gun, measured course or GPS.

When the unit is in digital speed display mode, push and release **M** to put the speedometer in the calibration mode. Push and hold **M** down for at least two seconds; the LCD will show “ADJUST.”

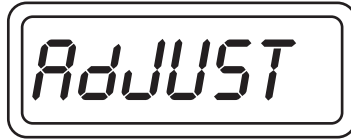

Calibration Display

CORC117

Run the boat at a constant 30 MPH as measured by the GPS, radar, or closed course. Adjust the speedometer pointer by pressing **▲** and **▼** until the speedometer matches the known speed.

When finished, press **M** to exit the adjustment screen. The operator has the option of saving or canceling the adjustment procedure. The options can be selected using **▲** and **▼**. To save the calibration setting, press and hold **M** for two seconds when the display shows “SAVE.”



Save Display

CORC118



Controls and Indicators

To exit the adjustment procedure without saving, press and hold **M** for two seconds when the display shows “NO SAVE.” Multiple runs in opposite directions may be necessary to compensate for errors due to water currents.

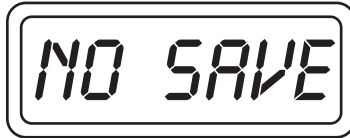

No Save Display

CORC119

Depth Sounder Function

To display depth information on the LCD, push and release the **M** until the display shows the depth. The depth sounder is turned on and off with the ignition switch. The depth sounder can also be turned off at any time, while in depth display mode, by pressing and holding **M** while the depth sounder counts down a three second delay.

The depth display will then indicate “OFF.”

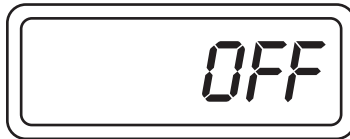

Off Display

CORC120

Press and hold the **M** to turn the depth sounder back on.

When there are no alarm conditions, the water depth is displayed. If the signal is weak or lost, or there is no transducer connected, the display will alternate between the last known depth and four horizontal bars.



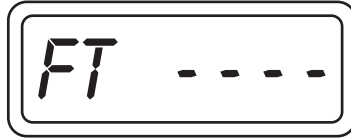

Depth Display

CORC121

Canceling Depth Alarms

A depth alarm warning can be temporarily canceled by pressing both ▲ and ▼ on the speedometer, simultaneously. After one minute, the alarm will resume if the condition that caused the alarm is not corrected. The operator can cancel the alarm as many times as necessary, until the condition is corrected.

The depth alarm warning will replace any information on the LCD screen. Canceling the alarm will restore the LCD to the original display. If not already in the depth mode, this would be a good time to switch to it (using **M**) in order to monitor water depth.

Depth Sounder Alarm Settings

NOTICE

*The speedometer display must be in the depth display mode to change settings. Use the **M** to scroll to the depth display.*

To change the depth sounder alarm settings, **M** must be held down until the depth display changes to the alarm settings mode.

There are four menus in the alarm settings mode. Pressing and releasing the mode switch quickly will cycle through the different options.

Shallow Alarm

This alarm sounds when the water depth equals or is less than the set value.

The display will show “S X.X” which is the current setting for the shallow alarm. Pressing ▲ and ▼ will change the shallow setting.

Controls and Indicators



Shallow Display

CORC122

Holding **M** in for two seconds will save the new shallow setting and change the display back to the normal depth mode. Set to zero to disable the alarm.

Deep Alarm

This alarm sounds when the water depth equals or is greater than the set value.

The display will show “d XX.X” which is the current setting for the deep alarm.



Deep Display

CORC123

Pressing ▲ and ▼ will change the deep setting.

Holding **M** in for two seconds will save the new deep setting and change the display back to the normal depth mode. Set to zero to disable alarm.

Keel Offset

Adjust depth sounder to measure depth below keel or drive instead of sensor.

The display will show “K X.X” which is the current setting for the keel offset. Pressing ▲ and ▼ will change the keel-offset setting.



Section 4



Keel Display

CORC124

Holding **M** in for two seconds will save the new keel offset setting and change the display back to the normal depth mode. The keel offset is normally a negative number.

Units

Change the unit of measure.

This display will show “UNIT FT” for feet (default), “UNIT FA” for fathoms, or “UNIT M” for meters. Pressing ▲ and ▼ will cycle through the choices. Pressing and holding the **M** will save the units shown in the display and change the display back to the normal depth mode.

Controls and Indicators



Feet (default)



METERS



FATHOMS

CORC125

Tachometer/Fuel Monitor

The tachometer/fuel monitor provides both the functions of a tachometer and a fuel-engine monitoring system. The analog tachometer looks like a standard analog device but is actually a digital instrument. On smaller pointer movements, you may occasionally see the pointer moving in the one-third degree “steps” that represent the accuracy of the instrument.

The tachometer LCD screen displays several user selected functions. The displayed data includes: “engine hours,” “time remaining,” “engine temperature,” “oil pressure,” “system voltage” and engine alarm conditions.

Pressing the “mode M” button will select the various functions as shown in the Tachometer Display Sequence.

In order to minimize “false” alarms, the “low voltage” alarm only functions when the engine is known to be running based on the presence of tachometer data.



Section 4

Engine Hour Meter

Displays the number of hours the engine has been operated. The display will show “XXXX.XHr.” Engine hours only accumulate when the engine is running.



Hourmeter Display

CORC126

Hours Remaining

The “time remaining” display shows the approximate number of hours the boat can operate based on the fuel remaining in the tank and the current fuel usage rate. The display will show “XXXX.XHrL.”



Hours Remaining Display

CORC127

Engine Temperature

Displays the coolant temperature of the engine. There are no adjustments available.

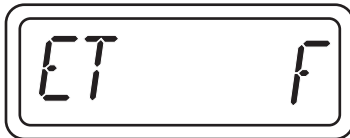

CORC205



Controls and Indicators

Voltmeter

Displays the system voltage. There are no adjustments available.



Voltmeter Display

CORC129

Oil Pressure

Displays the current oil pressure. There are no adjustments available.



Oil Pressure Display

CORC130

Instrument Lights

The navigation light switch must be on for the instrument lights to function. The ▲ and ▼ on the tachometer control the instrument lighting intensity.

Press ▲ to increase the light intensity. Press ▼ to decrease the light intensity.



Section 4

Tachometer Display Sequence

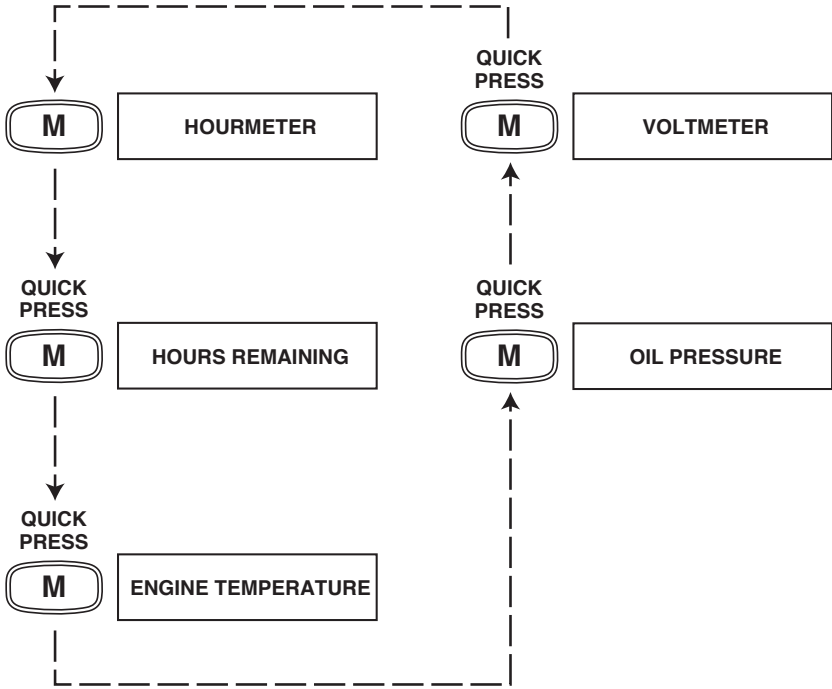

CORC131

LCD Alarm Condition Displays

Alarm messages will be displayed on the tachometer LCD display. All messages will be displayed until either the problem is corrected or the operator manually cancels the warning message.

Messages will display as many screens shown sequentially.

Canceling System Alarms

To manually cancel system warning messages, simultaneously press both ▲ and ▼ on the tachometer. This will disable the warning message temporarily. If the problem is not corrected in one minute (five minutes for low fuel), the warning will be displayed again. The operator can cancel as often as needed.



Controls and Indicators

Severe Conditions – Includes a Flashing Red Light

WARNINGS

Low Battery Voltage (Flashing Red Light)



High Engine Temperature (Flashing Red Light)



Low Oil Pressure (Flashing Red Light)



RPM Reduction in Progress (Flashing Red Light)



CORC132a

Engine Speed Limiter Active



Knock Detection System Malfunction



Spark Delivery System Malfunction



Manifold Pressure System Malfunction



Manifold Air Temperature Sensor Malfunction



Throttle Position Sensor Malfunction



Coolant Temperature Sensor Malfunction



CORC134



Section 4

Power Management Access (PMA) Panel

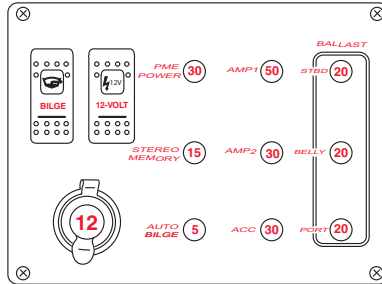

Your Nautique is equipped with a PMA panel to manage other components of the electrical system. It includes breakers, switches and a 12-volt port.

Bilge

This switch is meant to turn on the bilge pumps when the battery selector switch is set to OFF, thereby minimizing battery drain.

12-Volt Recept.

This switch is meant to turn on the 12-volt ports when the battery selector switch is set to OFF, thereby minimizing battery drain.

12-Volt Port

This receptacle can be used to power and charge cellular phones, MP3 players, video cameras or other electronics. This receptacle is powered through a 10-amp breaker. Limit the amperage to 10 amps.

Circuit Breakers

The circuit breakers are the manually reset type. A tripped circuit breaker will extend. To reset, press in the extended circuit switch shield. If a breaker continues to trip, this may indicate a problem. Contact your Nautique dealer and have the problem corrected.



Battery Selector Switch

The battery selector switch allows you to isolate the boat from the batteries, and switch from one battery to the other, or even operate on both batteries. The identification of each battery as well as the position allowing both to be used may differ depending on the switch manufacturer; however, with any switch it should be easy to determine how to select the desired configuration.

Under normal conditions, the switch should be set to one battery or the other and almost never to the position for both batteries. This will keep one battery in reserve should the other fail. Battery selection should be done when the engine is off. Alternate batteries daily. The switch can also be set to a position that turns off both batteries isolating the boat from the batteries.



WARNING

Avoid the possibility of personal injury or death from an explosion and/or fire. Never operate the boat with only one battery installed and the battery selector switch set to the position for both batteries. The positive battery cable end of the missing battery will be at full battery voltage and could short out against metal components possibly causing an explosion and/or fire.



Section 4

Dash Pod Circuit Breaker Box

All dash pod switches interface with a sealed circuit breaker box located behind the dash pod and access through the door on the port side of the dash. The circuit breaker box consists of 16 soft, opaque, flexible vinyl tubular shields which cover 16 circuit breakers. When the circuits are functioning, the tubular shield is somewhat flexible. A tripped circuit breaker will extend and fill the tubular shield, causing it to be inflexible. To locate a tripped circuit breaker, run your fingers over the two rows of switches and locate the switch shield which has become inflexible. To reset, press in the extended circuit switch shield.

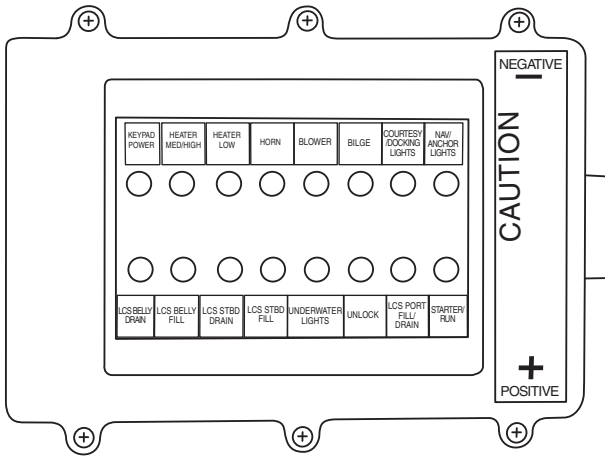

CORC035



Standard Equipment

Watersports Tow Point

The watersports tow point (pylon) is manufactured from high-strength stainless steel. If the pylon becomes loose, stop using the pylon and take the boat to your Nautique dealer for service.



WARNING

Misuse of the tow point can cause death or serious injury. The pylon was designed for water skiing only. **DO NOT** use for parasailing, kite flying, towing other boats and/or using pylon extensions; sit behind (aft) the pylon when towing skiers.

CAUTION

Although pylon extensions and barefoot booms have become popular additions to many tournament inboards, Correct Craft strongly objects and opposes the use of any pylon extension, whether up or to the side of any of its products. The use of pylon extensions can alter the handling characteristics of the boat, possibly resulting in dangerous instability, which could then lead to loss of control, a situation which could cause serious or fatal injury to the boat driver, passengers, skiers and anyone else who might be in the vicinity of such a mishap.



Section 4

CAUTION

Correct Craft DOES NOT approve of any structural changes, additions or modifications to our products. Any time a dealer or consumer makes a change to our product, they do so at their own risk and sole liability. Correct Craft, Inc. will not be held liable for unauthorized changes, whether deletions or additions, to the original equipment/product manufactured and sold by Correct Craft, Inc., even if such changes and additions are made by an “authorized” Nautique Dealer, customer, promotional representative or any other person, known or unknown to Correct Craft, Inc.

Bow Features of Your Nautique

The open bow section of your boat has removable cushions. The center section may be equipped with an optional cushion which can be removed and stored in the trunk or under the observer's seat. The cushion on the starboard side of the bow section can be removed to access the insulated cooler. Storage can be accessed by removing the other cushions.



Controls and Indicators

Driver's Seat Adjustment

The driver's seat can be adjusted fore and aft and rotates side-to-side.

To slide seat, turn the handle (A) counterclockwise about one full turn, slide into position, and tighten the handle hand-tight to secure in locked position.

To rotate seat, pull up on the lever (B) at the front of the seat and push to the side. Release lever to lock the seat in position.



WARNING

A seat or seats which are not locked in position can cause death or serious injury. Lock the seat(s) in position (fore and aft) before operating the boat.

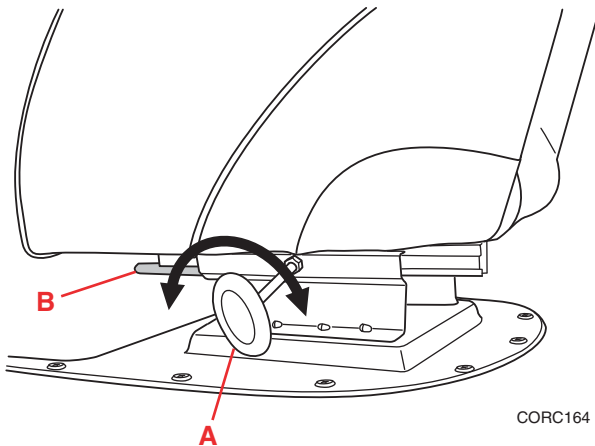

Section 4

Rearview Mirror Adjustment

The rearview mirror can be positioned on the windshield to observe a skier and traffic behind you. The mirror should be lowered when trailering or when using a mooring cover. To reposition, loosen the thumbscrews (**A**), reposition and tighten thumb screws.

Use the mirror friction nut (**B**) to increase the friction of the mirror adjustment. If the mirror moves out of adjustment, increase the friction by turning the friction nut clockwise.

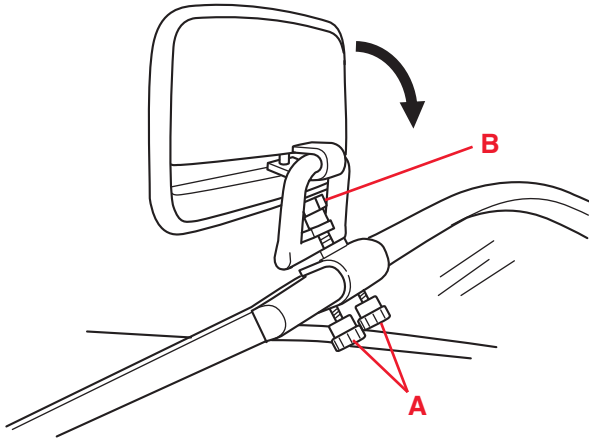

CORC165



Controls and Indicators

Observer's Seat (216V Only)

Lift up on the bottom of the observer's seat cushion to access storage under the bow area. You can leave the seat in the "UP" position to help dry the carpet.

Storage Hatch

To open the storage hatch, lift the latch and turn counterclockwise. The gas shock will help raise the hatch. To close and latch the hatch, pull down on the hatch and allow the hatch to close firmly. Make sure there are no hands, fingers or any other obstructions in the way of the hatch when you close it. To close the latch, turn the latch clockwise and fold the red dot down.

The storage hatch latch features a lock. Use the key to lock and unlock the latch. The key only requires about a 10° turn to lock and unlock.

Two dividers are installed in the engine compartments, which can be removed for service. The dividers must be in place when the boat is in use.

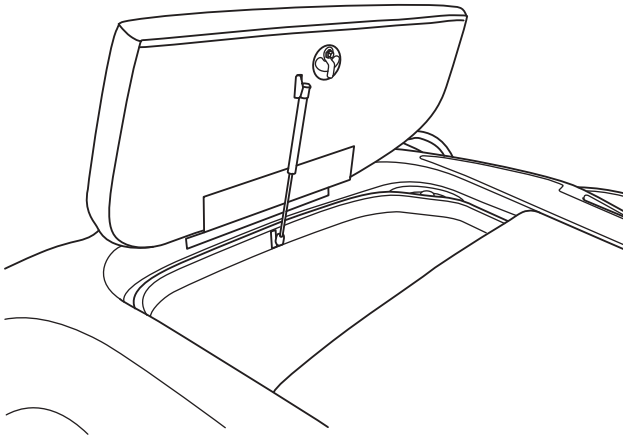

CORC146



Section 4

Engine Cover Hatch

To open the engine cover hatch, lift the latch and turn counterclockwise. The gas shock will help raise the hatch. To close and latch the hatch, pull down on the hatch and allow the hatch to close firmly. Make sure there are no hands, fingers or any other obstructions in the way of the hatch when you close it. To close the latch, turn the latch clockwise and fold the red dot down.

The engine cover hatch latch features a lock. Use the key to lock and unlock the latch. The key only requires about a 10° turn to lock and unlock.

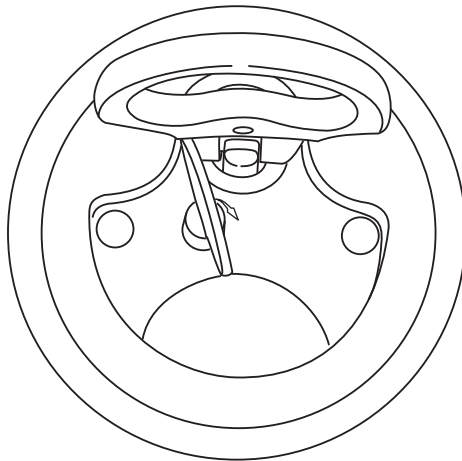

COR036



WARNING

An engine guard which is not in place or contact with any moving parts can cause death or serious injury. The engine box cover is a machinery guard. **DO NOT** operate your boat without the cover closed and in place unless you are performing a check or maintenance. Keep your hands, clothing, hair and any other body parts away from any moving parts.

Controls and Indicators

Walk-Thru Windshield Opening/Latching

There are two latches on the inside starboard side of the walk-thru windshield. Rotate both of the window locks (A) to secure or unlock the window. Always have window closed and secured when trailering the boat.

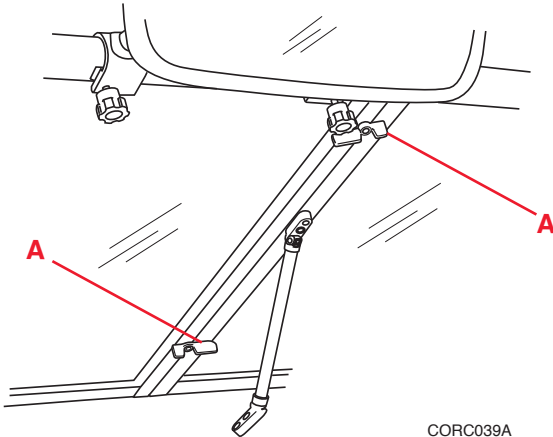

WARNING

An open window can cause death or serious injury. Make sure both window locks are secure when vessel is in motion.

Coolers

The floor coolers can be used to store miscellaneous items or drinks. There is a drain installed in the coolers. DO NOT depend on the coolers to keep valuables or electronics dry. Keep these items in a specialized dry bag. The floor cooler has a removable tray. DO NOT use abrasive cleaners or place in a dishwasher. Use a mild biodegradable soap only.



Section 4

Boarding Platform

The boarding platform of your boat is a convenient feature to enhance the watersports experience. There are serious safety concerns regarding the use of the platform. Correct Craft, Inc. has placed warning labels at the driver's position, on the deck at the rear of the occupant area and on the transom. Refer to Section 1, Safety, for more information.

To remove the boarding platform, pull the pins (A) located in the mounting brackets, under the platform and lift the platform vertically.

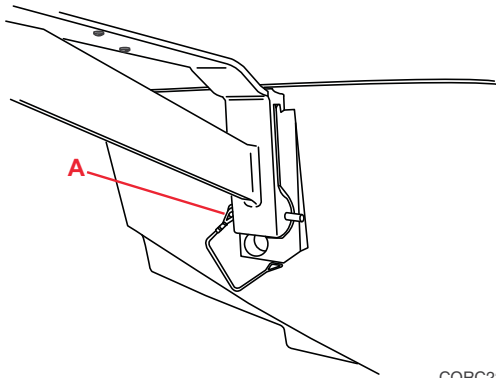

CORC226



WARNING

A spinning propeller or carbon monoxide can cause death or serious injury. DO NOT use the boarding platform when the engine is running or for any other purpose than boarding the boat or preparation for entering the water.

The boarding platform must be attached when the boat is in use.

Controls and Indicators

Engine Cooling Water Intake Valve

Your Nautique is equipped with a valve (seacock) on the engine cooling water intake. The handle has a slide mechanism to prevent the valve from being shut off inadvertently. The valve is used to shut off the water supply in the event a hose failure or water leakage occurs. The valve is open when the blue handle is in-line with the valve body and the valve is closed when the handle is perpendicular to the valve body. Leave the valve open at all times unless an emergency condition requires you to close the valve to stop a leak or the possibility of a leak.

The valve is located fore of the engine compartment. If your boat is equipped with a ballast system, the engine cooling valve (A) will be the first valve (larger valve), on the starboard side. The valve can be accessed by removing the built-in cooler, under the aft cockpit seat.

216V

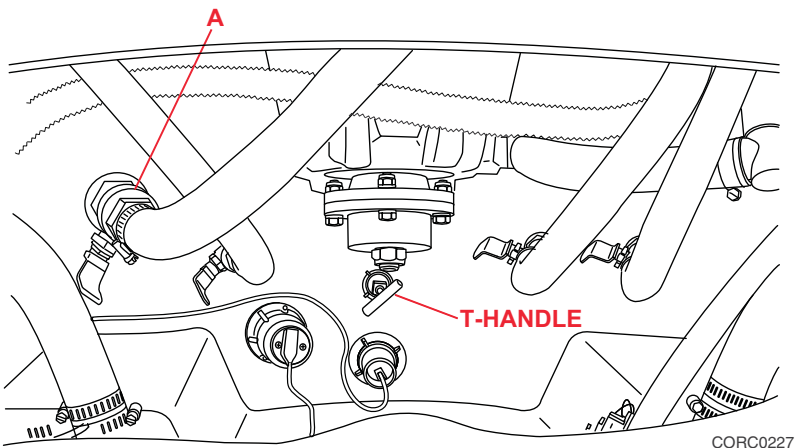

Section 4

226

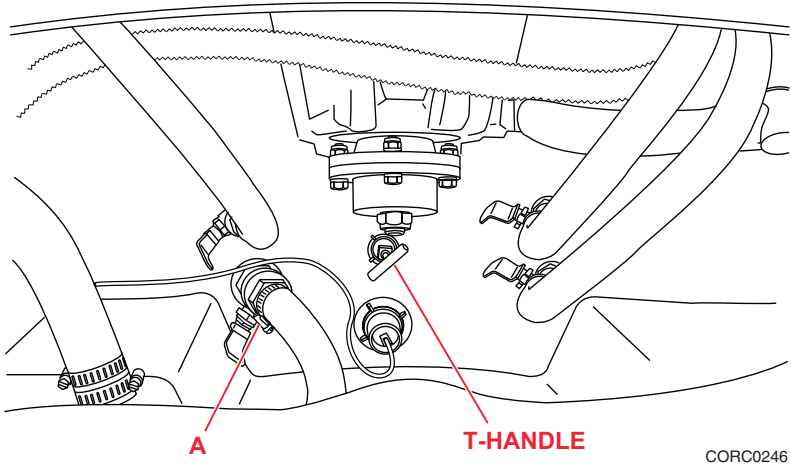

CORC0246



Controls and Indicators

Fuel Tank

There is a fuel tank fill cap on the port and starboard side for added convenience. Use the fuel tank fill cap key to remove the fuel fill cap to fuel your boat. Use caution when fueling your boat.

Avoid overfilling of the tank by monitoring the fuel level gauge while fueling. Turn on the ignition without starting the engine and monitor the gauge. Stop fueling as the gauge approaches the 'full' level and turn off the ignition when finished. Fuel spillage on our waterways will pollute our environment.

The fuel tank is located beneath the cockpit deck, in the center of the boat. To inspect the hose connections, raise the access panel. Your Nautique dealer should perform all fuel tank service.



WARNING

Explosion or fire can occur under certain conditions, causing death or serious injury:

- **Turn the engine off.**
- **DO NOT smoke or allow open flame or sparks within 50 feet (15 meters) of the refueling area.**
- **DO NOT refuel unattended; avoid contact and spilling.**
- **DO NOT refuel indoors.**
- **DO NOT use a plastic funnel.**
- **DO NOT allow any spilled fuel to remain on your boat's finish.**
- **DO NOT allow a fuel system problem to go unchecked.**
- **Always maintain contact with the fuel nozzle and the fuel tank to prevent electrostatic spark.**



Section 4

Folding Instructions for Flight Control Tower™ – Optional



WARNING

Crush hazard. The Flight Control Tower is heavy. Use care to fold or unfold the tower.

Flight Control Tower™ Series 3 (FCT 3)

Remove all boards from the board racks prior to folding the tower. Make sure to support the tower before unlocking the tower lock handles.

To Lower

Support the tower. Push the lock handles (A) down and rotate fully, until they stop. Gently lower the tower ensuring it does not make contact with anybody or part of the boat.

To Raise

Make sure the handles are in the fully open position before raising the tower. Slowly raise the tower into position making sure nothing interferes with a smooth seating.

With the tower in the fully upright position, turn the lock handles (A) upward until they stop. The handles will be horizontal when locked properly.

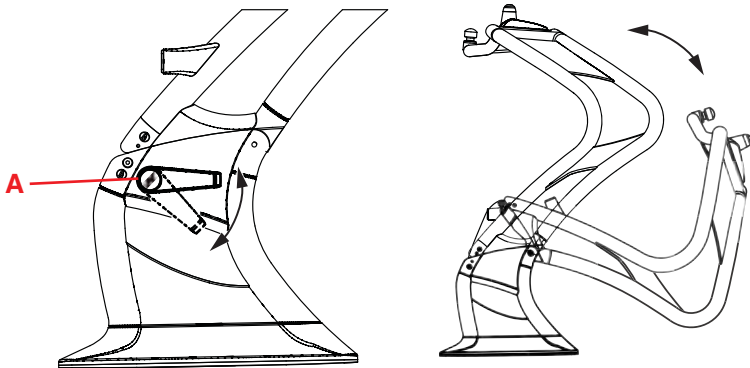

CORC0222

NOTICE

DO NOT leave the tower speakers facing forward while the boat is underway or trailered. Make sure they are facing aft and secured.



Controls and Indicators

If your tower is equipped with the optional tower speakers, they can be adjusted for redirection of sound by loosening the speaker mounting hardware and adjusted. Make sure the hardware is securely tightened after it is loosened.

Nautique towers are pre-wired so audio speakers can be added to the tower. The plugs have a “fish line” to retrieve speaker wires through the towers.

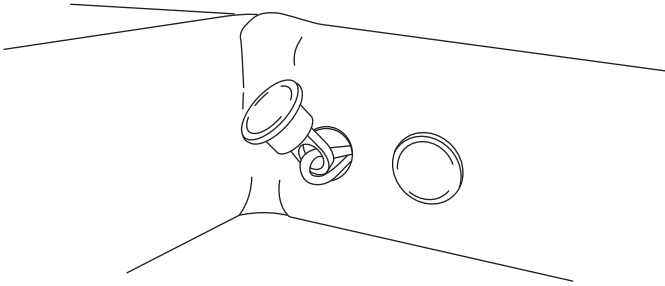

CORC0235

Anchor Storage Locker

Your Nautique features an anchor storage locker to support a danforth anchor.

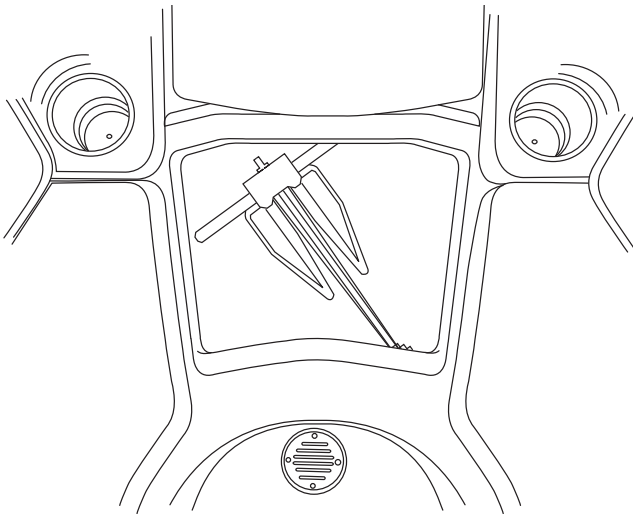

COR0236



Section 4

Engine Compartment Air Intakes

The intakes which supply fresh air into the bilge area are located aft, at the windshield frame base. The intakes must remain clear to allow air to enter the bilge area. **DO NOT** drape towels or any items which may not allow air to be drawn in while the bilge blowers are operating.

Bimini Top

Your Nautique may be equipped with a bimini top which can be used for securing lighter watersports equipment. The top can be tilted by removing the aft pins (A) and allowing the top to tilt, to load the equipment. Make sure the equipment is secured before getting underway. **DO NOT** exceed 90 lbs. (40.8 kg) or trailer with equipment on top.

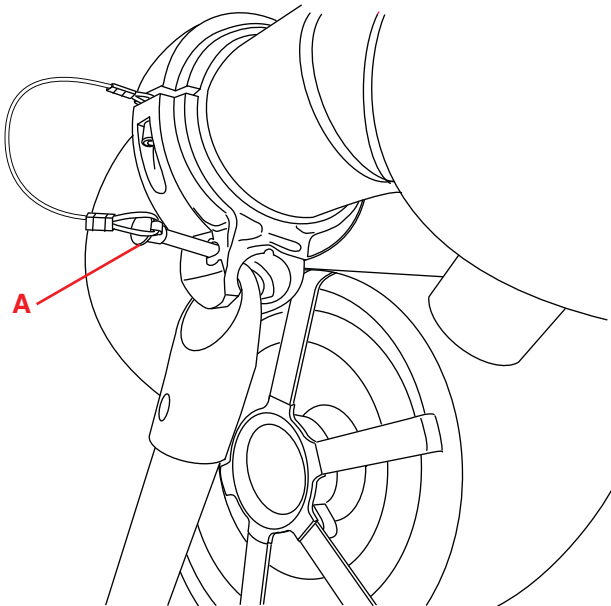

COR0237

Controls and Indicators

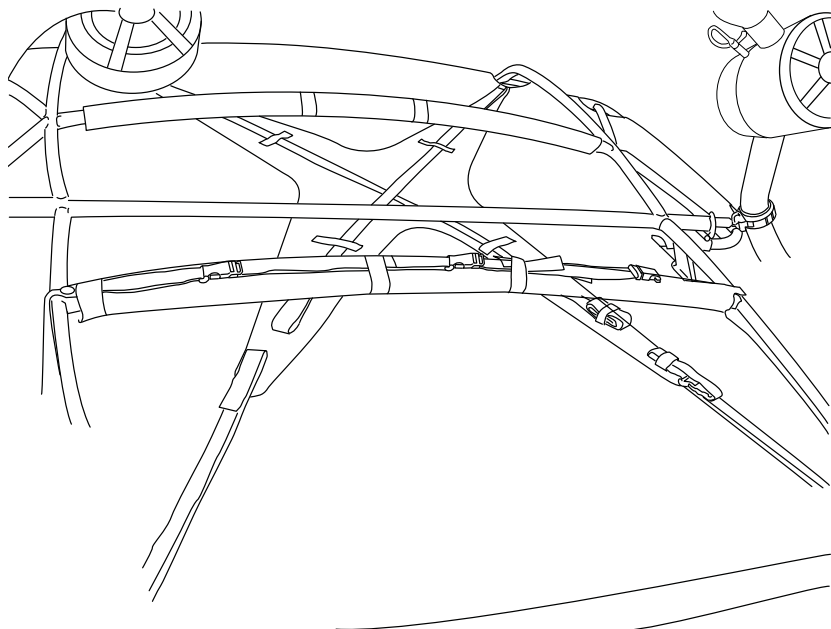

COR0238



Section 4

Ballast Tanks

The tanks increase the wake for wakeboarding, making your Nautique the most versatile watersports tow package in the world.

Ballast Tank Control Switches

Press the button for the ballast tank you choose to fill or drain.

To fill: Press and release quickly; the LED will illuminate and the pump will begin to fill the tank. Press the button again to stop the pump. Use the tank gauge to measure the level of water in the tank.

If you continue to fill the tank beyond its capacity, the excess water will expel from the tank vent. The pump will continue to operate for approximately 10 minutes if the pump is left in the fill mode, then shut off.

To drain: Press and hold the button until the LED begins to flash and the pump will begin to drain the tank. Press the button again to stop the pump.

The pump will stop pumping when the tank sensor senses the “No Water Level” in the tank. The LED will continue to flash for approximately 10 minutes unless the button is pressed again.

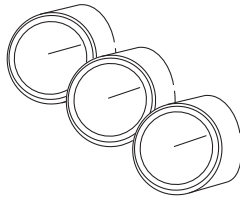

CORC208A

Ballast Control Gauges



Optional Accessories

Stereo and Speaker Pods

All Nautique boats are stereo ready and include an auxiliary input. They have been pre-wired for your Nautique dealer to install a stereo. Limited and Team Edition Nautique boats come with a Clarion stereo with Polk Audio speakers. Tower speakers can be purchased as an option. Nautique mounts all of its stereos in the glove box on the dash. A digital remote control can be mounted on the lower left side of the dash pod. The digital remote control displays all necessary control functions at your fingertip. See your Nautique dealer for the stereo configuration for your boat.

The audio speakers of your Nautique boat are designed to deliver maximum fidelity in a marine environment. The speakers can be damaged if struck by a sharp object or if the moving elements are restricted from movement. Do not store or place any sharp objects near the speakers, or restrict element movement.

Optional accessories are available from your Nautique dealer. Your dealer may have a wide range of other accessories available to enhance your watersports or pleasure boating experience. Contact your Nautique dealer for more information. Here is just one of the fine accessories Nautique offers:

- Pull-out Cleats

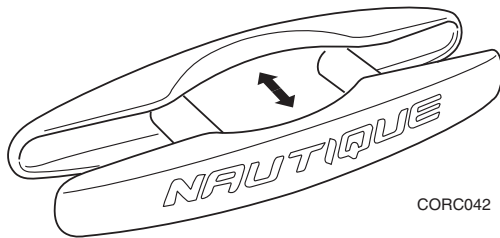

NOTES





Section 5

Boat Systems

Knowing the systems, controls and indicators on your boat is essential for safe and proper operation.



WARNING

Systems which are not inspected regularly or maintained can cause death, serious injury or damage to product. Inspect and maintain all systems to prevent unexpected hazards associated with worn or faulty components.

When replacement parts are required, use marine grade parts with equivalent characteristics, including type, strength and material.

Marine grade parts are designed specifically for the conditions and environment they are exposed to. Using substandard parts could result in injury and product failure.

Fuel System

The fuel system consists of a built-in fuel tank, a port fuel fill, a starboard fuel fill, a fuel tank vent, an in-line filter and a sending unit to measure fuel level.

The fuel tank is located under the cockpit floor. To inspect, lift aft seat base and removable section of the cockpit floor.

Section 5

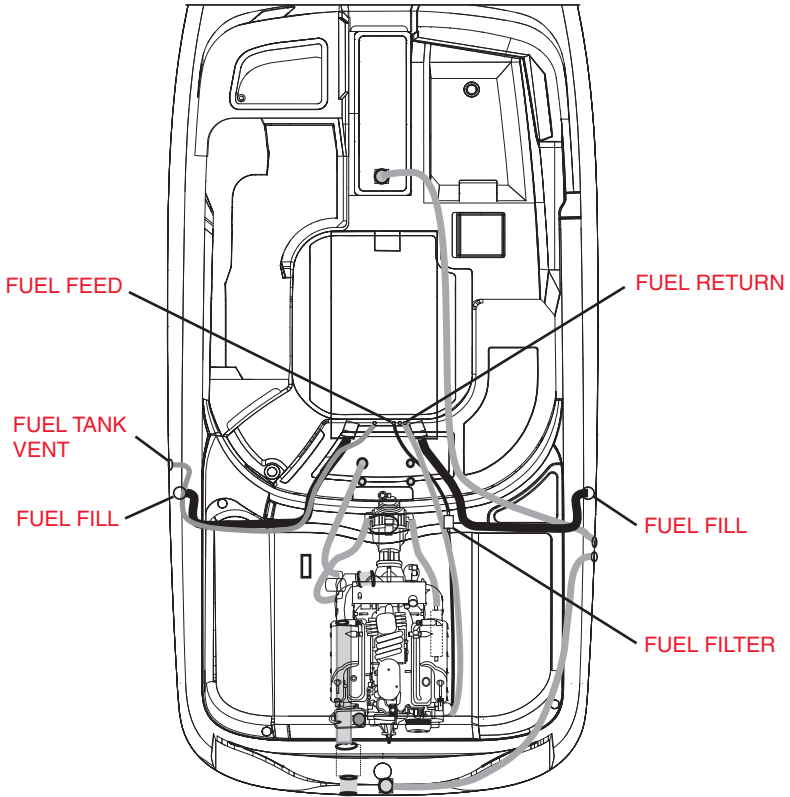

CORC0243



Ballast Tanks and Bilge System

NOTICE

The Federal Water Pollution Control Act prohibits the discharge of oil or oily waste into the water. Violators can be fined \$5,000.00.

Do not allow water to accumulate in the bilge area of your boat. When the boat is in use, make sure the bilge pump is turned on. The bilge pump is an automatic pump that tests for the presence of water every two to three minutes and pumps until the water is removed. If the pump is in between detection cycles, the detection mode can be bypassed to operate immediately by turning the switch off and then back on. Remember, the engine and other parts of the drive system could be damaged and there is also a risk of personal injury as increasing water level will adversely affect the handling and maneuverability of the boat.

CAUTION

The risk of personal injury from excess water in the bilge area will adversely affect the handling and maneuverability of the boat. Also, damage to the engine and other parts of the drive system can occur from the additional water. DO NOT allow the bilge pump to operate after all the water has been cleared from the bilge area; damage to the pump will occur.

European market boats include filters in the bilge drain hoses. These filters are designed to reduce the amount of contaminated bilge water being drained into waterways. The filters are located on the starboard side of the engine compartment, under the gunwale. Follow the filter manufacturer's recommendations on when they must be replaced.



Section 5

Ballast Tank Valves - 216V

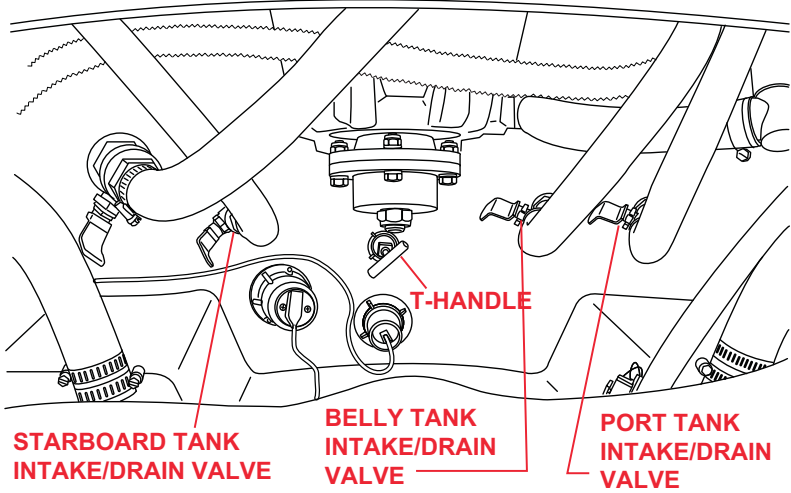

CORC0227A

Ballast Tank Valves - 226

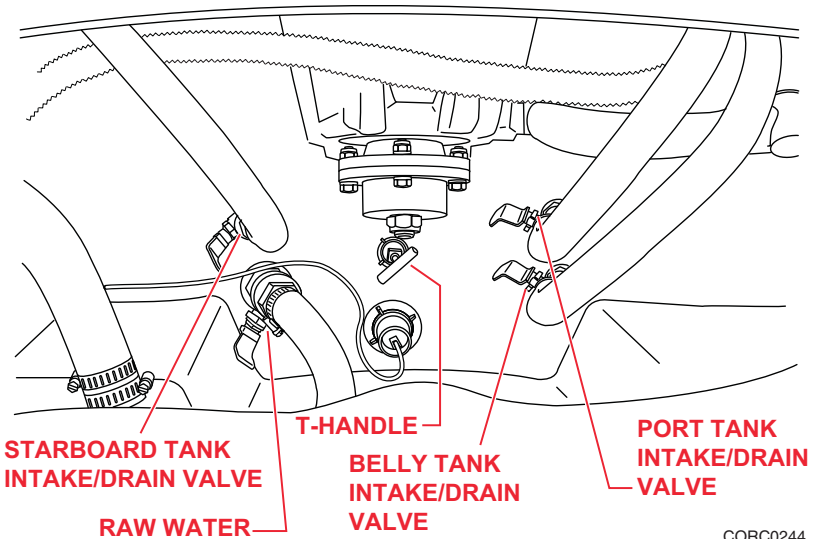

CORC0244



Belly Ballast Tank and Bilge System

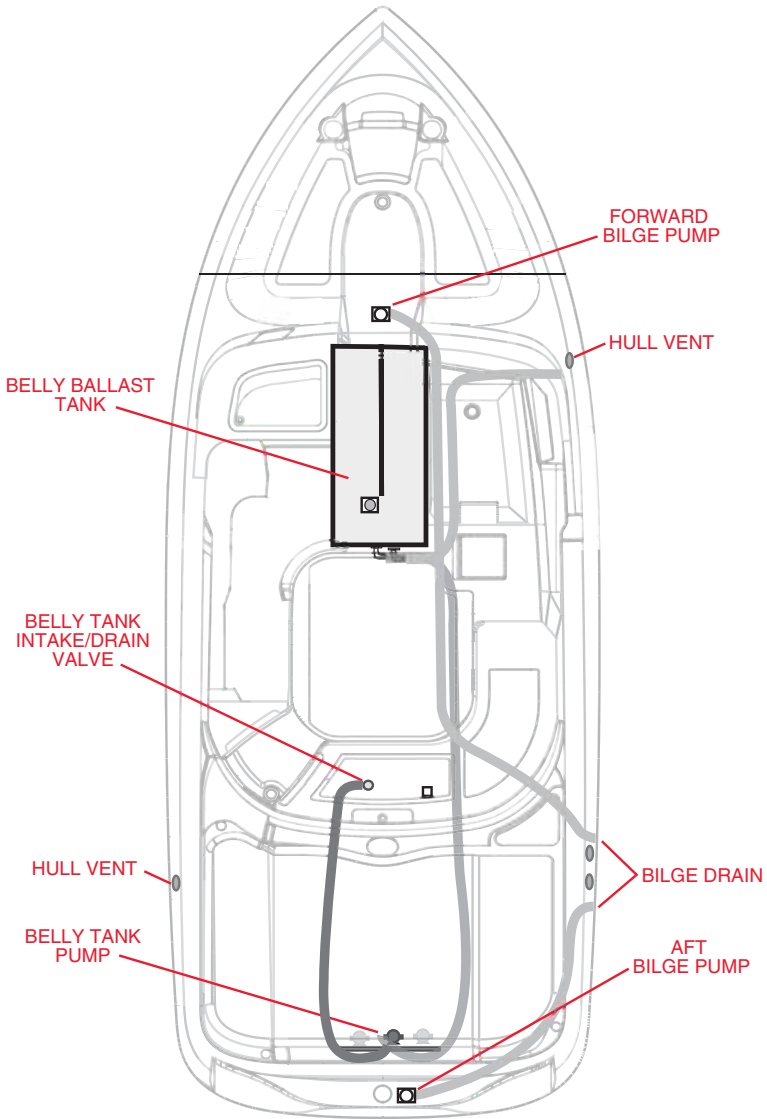

CORC0229



Section 5

Port and Starboard Ballast Tanks

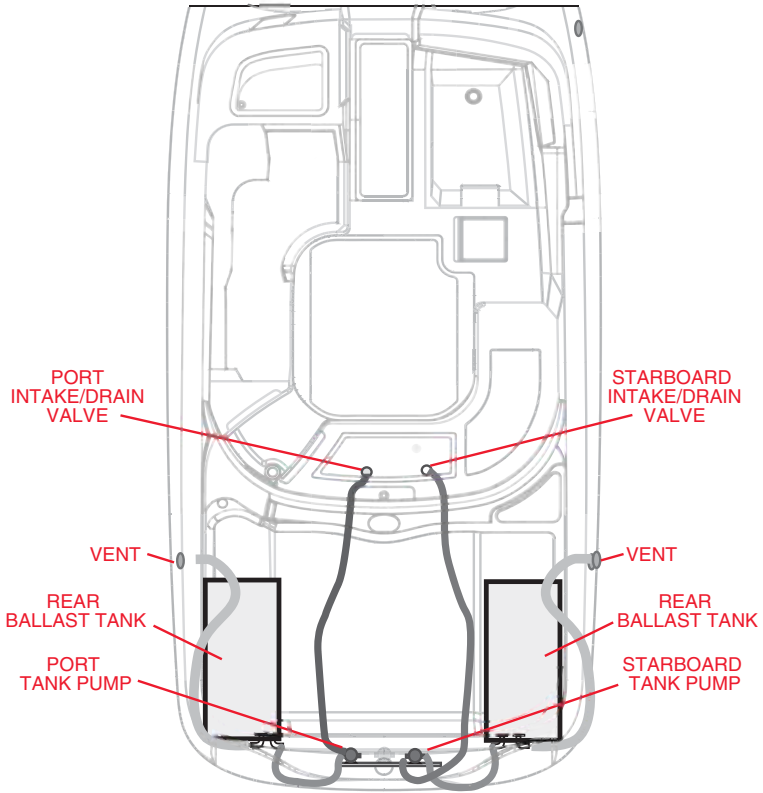

CORC0230



12-Volt System

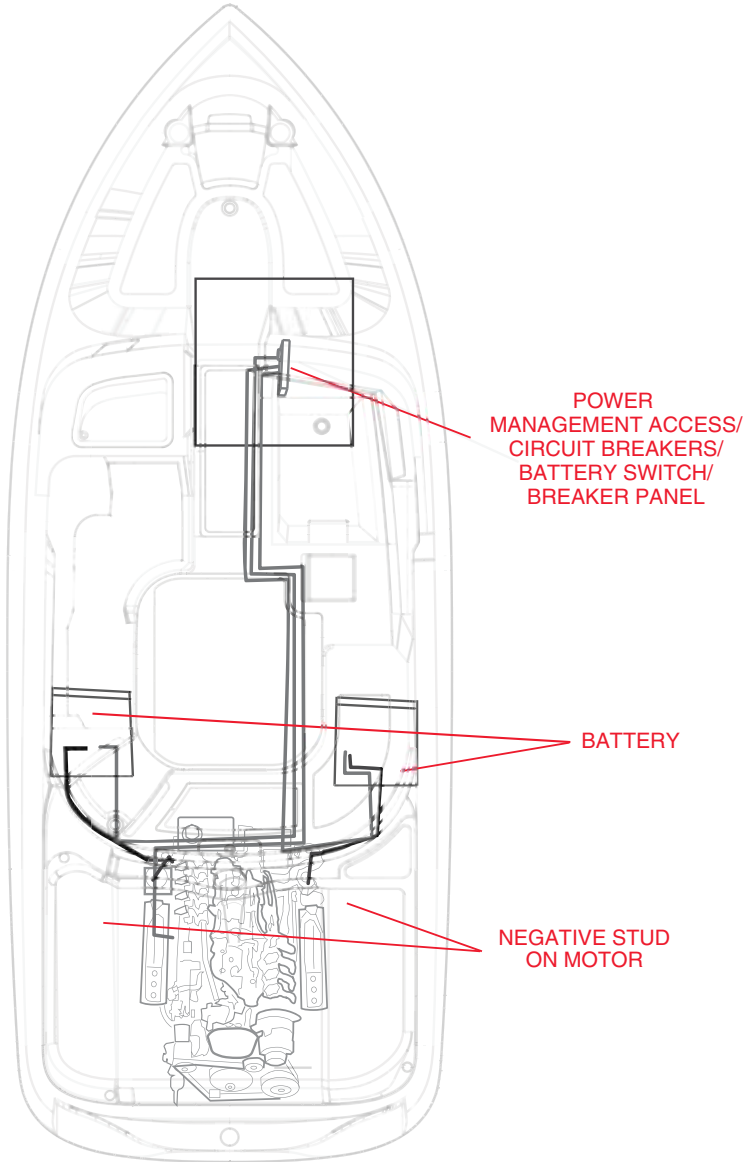

CORC0233



Section 5

Heater System-Optional

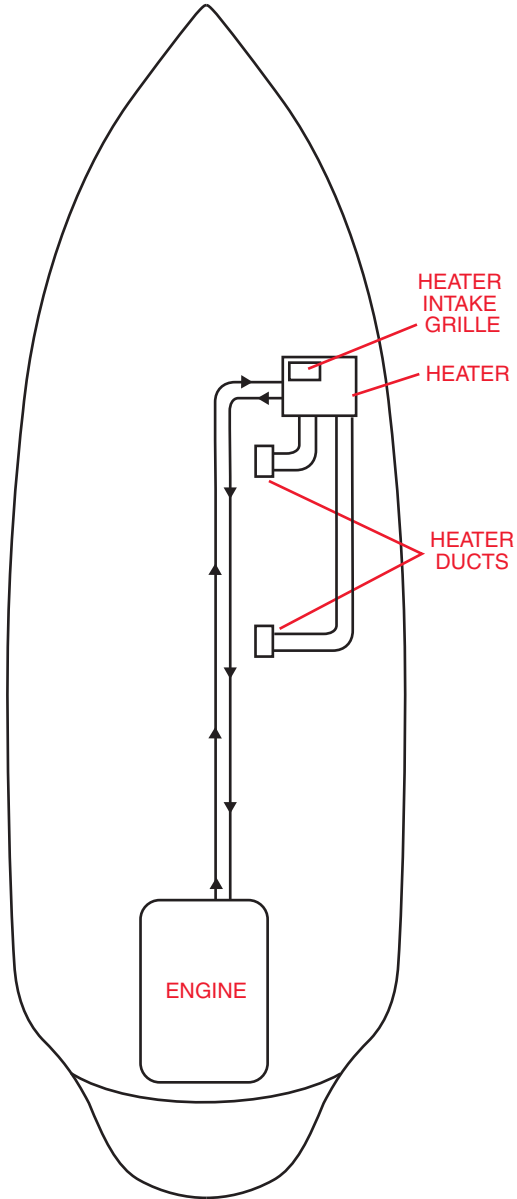

CORC0231



The heater system has a heating core, ducts, diffusers and a three-speed fan to deliver heat to the cockpit and windshield. The duct diffuser at the windshield can be closed and rotated to direct air flow. The floor ducts can also be closed to control air flow. The aft duct and diffuser can be pulled out of its socket to direct flow in other locations of the cockpit. The heating unit is located under the driver's dash pod.



NOTES





Section 6

Getting Underway

There are many things to consider to make your boating trip safe and enjoyable. You are responsible for the safety of all passengers, the boat and any damage the boat or its wake may cause. Keep passengers from blocking your view so that you do not run into other boats, swimmers, water skiers, personal water vehicles or aids to navigation.

Safety Checklist



WARNING

Operating the boat if any problem is found during this inspection can cause death or serious injury. DO NOT operate the boat if any problem is found during this inspection.

Problems found during this inspection should be handled by your Nautique dealer.

The following checks are essential to safe boating and must be performed before starting the engine.

- Check the weather report, wind and water conditions.
- Check that required safety equipment and PFDs are on-board and in proper operating condition.
- Check that the fire extinguisher is fully charged.
- Be sure the boat is not overloaded.
- Be sure the operator's visibility is not obstructed.
- Check that all maintenance has been performed.
- Check the fuel system for leaks and fumes.

Section 6

Safety Equipment

Federal and local laws require certain safety equipment to be on-board at all times. In addition, responsible boaters carry other equipment in case of emergency. Check with local boating authorities for any additional requirements over and above the federal requirements.

Fueling



Explosion or fire hazard. Gasoline is extremely flammable and highly explosive under certain conditions. Turn the engine off and DO NOT smoke or allow open flames or sparks within 50 feet (15 meters) of the fueling area. Check your boat for fuel leaks and fumes before, during and after each use. Maintain contact between the fuel nozzle and the fuel tank to prevent electrostatic spark. DO NOT use a plastic funnel.

CAUTION

To prevent engine damage not covered by warranty, refer to your engine operation and maintenance manual for recommended fuel type and octane rating.

Take care not to spill gasoline. If gasoline is accidentally spilled, wipe up all traces of it with dry rags and immediately dispose of the rags properly ashore. Spilled fuel may “yellow” the gelcoat finish and damage gunwale trim.



Gasoline Containing Alcohol

CAUTION

DO NOT use any gasoline that contains **METHANOL**. This fuel is very corrosive and will create unsafe operating conditions to the boat's fuel system and serious damage to the engine. Any engine damage caused by the use of methanol will not be covered by the engine's warranty.

The implementation of ethanol-based fuel is spreading rapidly throughout the United States. As such, PCM Engines and Nautique provide the following information regarding the use of this fuel. This information addresses the use of ethanol fuels in PCM Engines and Nautique boats.

CAUTION

Use of ethanol blended fuel rated E10 or less is acceptable. DO NOT use fuels rated higher than E10. Ethanol fuels rated higher than E10 could potentially damage the engine and/or present an unsafe boat fuel system. Damage to the engine resulting from the use of ethanol fuel rated higher than E10 **IS NOT** covered by the engine's warranty.

If ethanol blended fuel rated E10 or less is used, or if the presence of alcohol is uncertain, inspections and service of the complete fuel system are required more frequently. Any sign of fuel leakage or deterioration must be repaired immediately before further engine operation. It is also important to know that ethanol blended fuel will act as a solvent and will attract and hold moisture.

NOTICE

Fuel system or engine damage caused by contamination from water, foreign particles, sludge, or gums entering or forming in the fuel system is not covered by the engine's limited warranty.



Section 6

Without proper fuel filtration or fuel stabilization, ethanol blended fuel may cause the following:

- Excessive moisture (water) can cause lean operation, hard starting, and operating difficulties such as vapor lock and low speed stalling, and can reduce fuel shelf life.
- Ethanol blended fuels acting as solvents can cause gum, sediment, sludge and other particles to be loosened and carried through the fuel system to the engine.

Fuel Stabilizer Recommendations for Ethanol Blended Fuels

The use of a commercially available fuel stabilizer, such as STA-BIL[®], is recommended when storing ethanol blended fuel for more than two weeks.

When fueling:

1. Avoid fueling at night, except under well-lighted conditions. Also avoid overfilling of the tank by monitoring the fuel level gauge while fueling. Turn on the ignition without starting the engine and monitor the gauge. Stop fueling as the gauge approaches the 'full' level and turn off the ignition when finished. Fuel spillage on our waterways will pollute our environment.
2. Moor your boat securely to the dock. Know the location of the fire extinguisher in case of emergency.
3. Close all doors, hatches, windows and other compartments.
4. Extinguish cigarettes, pipes and all other flame-producing items.
5. Make sure all power is off, and **DO NOT** operate any electrical switches.
6. Add fuel in accordance with the engine operator's manual. **DO NOT** overfill, and allow enough room for fuel expansion.

After fueling:

1. Tighten the fuel filler cap. Wipe up any spilled fuel.
2. Check all fuel lines, hoses and connections for leaks and deterioration.

NOTICE

Each time you refuel, inspect all fuel lines, hoses and connections for leaks and deterioration.



Boarding

When boarding the boat, always step in. DO NOT jump. Avoid stepping on fiberglass or other potentially slippery surfaces. Board one person at a time.

DO NOT board the boat while carrying gear. Set the gear on the dock, board the boat and then pick up the gear.

Use the boarding platform to board from the water. To prevent injury, make sure the engine is off when swimmers, divers and skiers are boarding or even near the platform.

Boat Planing

The performance of your Nautique boat depends on load weight and distribution. DISTRIBUTE WEIGHT EVENLY, from bow to stern, and also from port to starboard.



WARNING

Overloading of passengers, personal equipment and supplies could result in an accident, especially in rough waters.

If your boat is equipped with a ballast tank or loaded, loss of horizon may occur when you begin to plane your boat. Get on plane immediately to restore the vision of your path. DO NOT operate your boat if the loss of horizon prevents you from operating it safely.



Pre-Operation Checks

It is the owner's responsibility to check all of the items listed below to be certain all preparation steps are completed before you use your boat. Checking these items periodically will soon become a habit. If leaks or other abnormal conditions are found, stop using the boat and contact your Nautique dealer to have the problem corrected.

Get into the habit of performing these checks in the same order each time so that it becomes routine.

- Make sure to check all safety items.
- Check that drain plug is properly installed.
- Check condition of propeller.
- Check that all batteries are fully charged and at the proper level.
- Verify the amount of fuel in the fuel tanks.
- Be sure the lights, horn, bilge pumps and other electrical equipment are in operating condition.
- Check that steering system operates properly.
- Make sure your float plan is submitted to a responsible person.
- Refer to your engine operation and maintenance manual for additional pre-operation checks.



Getting Underway

The following instructions are very important:

- Raise the engine hatch all the way up. Check to see if all the engine drain plugs are in place. Make sure the hull drain plug (T-handle) in the bilge area is installed.
- Look at all the hoses to make sure they are installed and the hose clamps are tight. Close the engine hatch and turn on the engine compartment blower. Run the blower at least four minutes to remove fuel vapors that might be in the bilge area and engine compartment before starting engine. Remember, if you have detected the presence of fuel vapors, do not start the engine until the source has been determined, problems corrected and vapors removed.
- **Check all gasoline line connections.** Connections are located at the fuel tank, the fuel control cell and the fuel injection system. All Nautique boats are equipped with anti-siphon valves on the outlet fittings of the fuel tanks to reduce the chance of fuel siphoning from the fuel tank if a fuel hose leaks or is severed.
- Fill the fuel tank and check for leaks. Check again for leaks after the engine has run for a few minutes.



Section 6

Checklist before starting boat:

1. Engine oil level - boat must be level.
2. Transmission oil level - boat must be level.
3. Shifting linkage and detent in FORWARD, NEUTRAL and REVERSE.
4. Leaks (water, fuel and oil).
5. Coolant level (closed cooling system).
6. Operation of the throttle and transmission shift control.
7. Battery condition.
8. Visually inspect for any loose mounting fasteners.
9. Verify the emergency stop switch located by the throttle is fully functional and the lanyard is not frayed or damaged. Clip the safety lanyard securely to your body. Keep it attached at all times while you are driving.
10. Check that engine cooling water (raw water) valve is open and raw water strainer is clean.

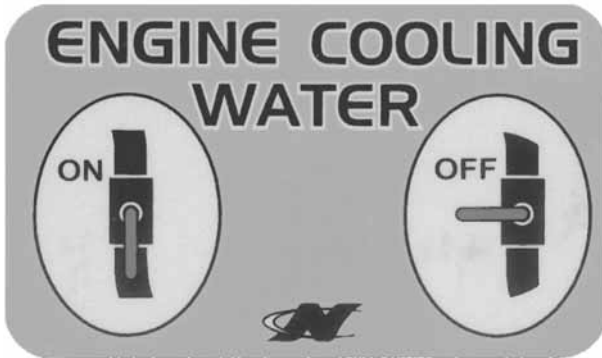

CORC015

- Once the boat is in the water, visually check for water leaking at the stuffing box. There should be no leakage from the optional “dripless stuffing box” while a conventional stuffing box must drip a moderate amount of water to properly lubricate the drive shaft. If the “dripless stuffing box” is leaking or water is coming in rapidly with the conventional stuffing box, pull the boat out of the water and have your Nautique dealer service the stuffing box.



Getting Underway

- Make sure there are no ropes, gear bags or arms/legs near the belts and pulleys of the engine. Severe injury can result by becoming entangled in the belts of the engine while it is running. Make sure the boat is deep enough in the water to supply the water intake with water to cool the engine. Move the throttle into the NEUTRAL “straight up” position.



WARNING

Fire or explosion hazard from fumes accumulating in bilge area. Ventilate the engine compartment by running the blower for four minutes, especially after repairing or refueling and check for fuel spills or leaks.

- Close the engine cover.



WARNING

An engine guard which is not in place or contact with any moving parts can cause death or serious injury. The engine box cover is a machinery guard. DO NOT operate your boat without the cover closed and in place unless you are performing a check or maintenance. Keep your hands, clothing, hair and any other body parts away from any moving parts.

- Start the engine.

CAUTION

DO NOT continue to operate the starter for more than 30 seconds without pausing to allow the starter motor to cool off for five minutes. This allows the battery to recover between starting attempts.



Section 6

In order to prevent personal injury to you or others, the engine cover must be closed whenever the engine is running.

- DO NOT operate the engine with the engine cover open or while someone is in the area of an open engine cover.
- DO NOT open the engine cover unless the engine is turned off and rotating parts are stationary and remain in a stationary position.

IT IS RECOMMENDED THAT ALL WORK ON THE ENGINE BE DONE BY TRAINED AND QUALIFIED SERVICE PERSONNEL.

During the warm up period, check the gauges for correct and normal operation of all the systems:

- Oil pressure 35-80 psi, at approximately 2000 rpm
- Cooling water flow and water temperature 140-170°
- Cooling water temperature for freshwater systems: 170-210°
- Volts should rise to around 13-14V or higher
- Idle rpm (600-700) in gear

CAUTION

DO NOT operate at high rpms in NEUTRAL.

DO NOT shift into FORWARD or REVERSE at engine speeds above idle rpms.

DO NOT operate the engine without a cooling water supply.

Damage to the water pump impeller and engine can occur. If the engine does not start, refer to Section 9, Troubleshooting.



If the engine does not start:

- If the fuel filter has been changed or if the fuel system was run dry, it will be necessary to cycle the ignition start button from the STOP position to the START position several times until the fuel pumps build adequate pressure. The cycling of the ignition is necessary because the fuel pumps will run only one to two seconds when the ignition is turned on, unless the engine starts. Keep the shifter/throttle control in NEUTRAL when starting the engine. If the throttle is advanced, the computer will think the engine is flooded and initiate a “clear flood” condition which will shut off fuel to the engine and not allow it to start. The idle speed increase is normally on hot or cold starts. This is programmed into the computer. When the engine starts, the idle speed will jump to approximately 1,500 rpm and quickly decrease to between 750 and 900 rpm.
- Check for gasoline and cooling water leaks on the engine.
- Check for cooling water circulation (look at the raw water strainer at the rear port side of the engine for water movement).

Flooded Engine

If your engine does become flooded, use caution when attempting to start the engine. Push in the transmission disengagement button at the bottom of the shifter/throttle control handle and advance the throttle to the FULL THROTTLE position. By pushing the button in, the shift linkage is disengaged and the transmission remains in NEUTRAL during the starting procedure. Run the starter until the engine starts. DO NOT operate the start switch for more than 30 seconds. Allow the starter to cool.

We suggest you bring your boat back to your Nautique dealer after 25 hours of operation for an inspection of the shaft alignment, stuffing boxes adjustment, and the fuel system checked for leaks. This is not a free service. Follow Pleasure Craft Marine’s (PCM) recommendations in the maintenance section for additional service to the engine. See your Nautique dealer to determine what charges will apply.



Section 6

When the engine starts, move the throttle lever back until the engine is running about 2,500 RPM or less. Check the gauges for normal readings and let the engine run for a minute to burn the excess fuel. If the gauge readings are abnormal, stop the engine and contact your Nautique dealer. When the engine runs normally, check the engine for fuel, water and exhaust leaks. If there are leaks, stop the engine and correct them before you continue.

NOTICE

Read the “Notice to Dealer” located in your Skipper’s Kit. It contains pre-delivery checks and adjustments which must be performed by your Nautique dealer. It is still the boat owner’s responsibility to make sure they were performed. This will also help you become more familiar with your boat and its systems. If you have any questions regarding this notice, contact your Nautique dealer.

After your initial run:

- Check the engine oil level
- Check the transmission oil level
- Check the V-Drive oil level
- Check for leaks (water, fuel and oil)
- Check that engine frame bolts and mounts are tight
- Check that throttle and shift control operates correctly

NOTICE

If the engine backfires when you try to start it, the problem may be more serious than flooding.

- ***DO NOT CONTINUE TRYING TO START THE ENGINE.***
- ***CONTACT YOUR NAUTIQUE DEALER OR A QUALIFIED TECHNICIAN TO CORRECT THE PROBLEM.***

DO NOT keep trying to start the engine under these conditions. Engine damage or personal injury can result.



Break-In Procedure

Make sure all your passengers are properly seated before starting the break-in procedure. After the engine is thoroughly warmed up and you have driven the boat into a large open area, advance the throttle to wide open until the maximum rpms are reached. DO NOT exceed 5,000 RPM. Reduce the throttle to 2,800-3,000 RPMs and cruise at or below this speed for 30 minutes. Reduce the speed to idle, advance the throttle to wide open and operate at that speed for one minute; reduce to the previous cruising speed for a few minutes and repeat. Accelerating from idle speed to wide open assists in seating the piston rings. This cycle can be repeated from time to time during the first five hours of operation. DO NOT operate engine at full throttle for longer than one to two minutes.

CAUTION

Follow these procedures only when conditions are such that you can drive the boat safely. DO NOT attempt to break in an engine by letting it idle at the dock.

Propeller Selection

The maximum RPM of the engine at full throttle under normal load conditions can be controlled by propeller pitch, diameter and design. It is essential the propeller does not underload or overload the engine.

Propeller Overloading – results in low RPMs at wide open throttle will give poor performance, poor fuel economy and eventually result in engine damage.

Propeller Underloading – if operated with a propeller that has too little pitch or diameter, poor performance will result.



NOTICE

Running your boat in shallow water can cause propeller shaft, strut, propeller and rudder damage and sand and silt to be pulled into the cooling system. This will cause excessive water pump wear and can clog the water passages in the engine. Heavy weed growth in the water can plug the raw water strainer and oil coolers and cause engine damage. There is a raw water strainer located near the rear of the engine to strain the water before it goes into the transmission cooler and then the engine. Check this every time you use your boat to make sure it is not clogged.

Refer to **Section 1, Hazardous Conditions, Boating Safety.**

If the engine fails to start or is not operating properly, contact your Nautique dealer for assistance.

Shifting



WARNING

Boat movement without making sure your path is clear can cause death or serious injury. Make sure there are no swimmers or obstacles in the water near you.

Keep the control lever clean and clear of obstructions. Refer to your engine operator and maintenance manual for shifting information.

Always pause in NEUTRAL before shifting from REVERSE to FORWARD and from FORWARD to REVERSE.

Steering

Practice steering your boat. Make sure the steering system is working correctly and is properly maintained.



WARNING

The steering system must be in good operating condition for safe boating. Frequent inspection, lubrication and adjustment by your Nautique dealer is recommended.



Stopping

Stopping the engine immediately after operating at high speed is not recommended. Allow the engine a two to three minute cool-down period at idle or low speed.

Refer to your engine operator and maintenance manual for stopping information.

Docking



WARNING

There is a crushing hazard between the boat and other objects that could cause death or serious injury. DO NOT use your hands, arms or another part of your body to attempt to keep the boat from hitting other objects, especially a dock.

Approach a dock slowly and use caution. Plan your maneuvers ahead of time. Allow wind and current movement to help maneuver your boat.

Come to a stop a short distance from the dock, then proceed slowly.

- Have your fenders and mooring lines ready.
- Observe how the wind and current are moving your boat. Approach the dock with the boat pointed into the wind, if possible.
- If possible, throw a line to a person on the dock and have that person secure a bow line. If no one is on the dock, maneuver as close as you can, then secure any line to a piling or dock cleat.

Before tying up your boat, be sure to use enough fenders to protect the boat from damage. If possible, tie up the bow toward the waves with a good quality double-braided nylon line. Tie up only to the lifting rings, tie-down eyes or cleats; DO NOT use the handrails or windshield frame. If the boat is to be moored for a long period of time, use chafing protectors on the lines to protect the gelcoat finish. Leave a little slack in the lines to allow for some wave movement or tidal action as applicable.

When departing, cast off the bow line and move away. If the wind or current is pushing away from the dock, cast off all lines and allow to drift until you are clear.



NOTES





Section 7

Running

Nautique urges you and all others operating your boat to seek certified instruction from the local boating authorities.

This section is designed to present the most basic operational principles. It is NOT intended to cover all conditions encountered during operation. Therefore, the principles in this manual are limited to the facts related directly to the operation of your boat, while the responsibility for the proper application of these principles belongs to you.

Maneuvering Techniques

Steering response depends on three factors: rudder position, motion and throttle.

Maneuvering in congested areas and advanced courses requires mastering and good “Rules of the Road” ethics. Your Nautique boat is designed to be responsive and agile enough to meet the challenge of these conditions.

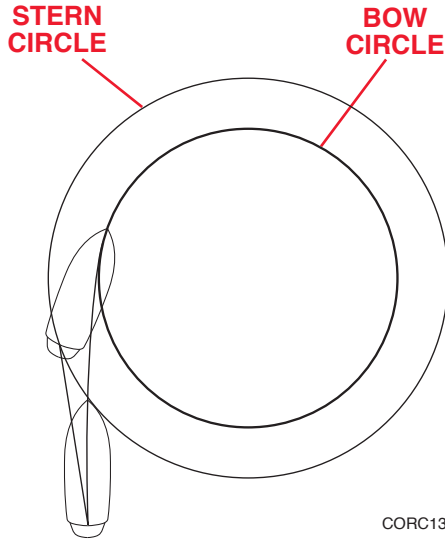

Maneuvering

High-speed maneuvering is relatively easy and takes little practice to learn. Slow-speed maneuvering is far more difficult and requires time and practice to master.

When making tight maneuvers, it is important to understand the effects of turning. Since both thrust and steering are at the stern of the boat, the stern will push away from the direction of the turn. The bow follows a smaller turning circle than the stern.



WARNING

Quick maneuvers can cause people and objects in the boat to be thrown about, resulting in death or serious injury. DO NOT make quick or high-speed maneuvers when you or your passengers are not prepared.



The effects of unequal propeller thrust, wind and current must also be kept in mind. While wind and current may not always be present, experienced boaters will use them to their advantage. Unequal thrust is an aspect shared by all single-engine propeller-driven watercrafts.

Your Nautique craft has a counterclockwise rotation propeller which tends to cause the boat, steering in the straight ahead position, to drift to port when going forward or backward. At high speed, this effect is usually unnoticed, but at slow speed, especially during backing, it can be powerful. For this reason, many veteran boaters approach the dock with the starboard side of the boat toward the dock, if possible.

Stopping (checking headway) is a technique that must be developed. Reverse thrust is used to slow and stop the boat. The momentum of the boat will vary according to the load as well as the speed. Make it a practice to slow to idle (no-wake) speed before shifting into reverse.

It is best to learn maneuvering skills in open water away from traffic. Adequate practice is the only way to develop your boating skills.

Tow Pattern

A large loop pattern is preferred for beginners. This pattern does not require the skier to cross the wake. As the skier's skills improve, a looped end or dumb bell pattern may be used. The dumb bell pattern provides a long straight course which allows the wake to disperse, leaving the skier with a smooth water surface. The dumb bell pattern is popular with ski tournaments and clinics.

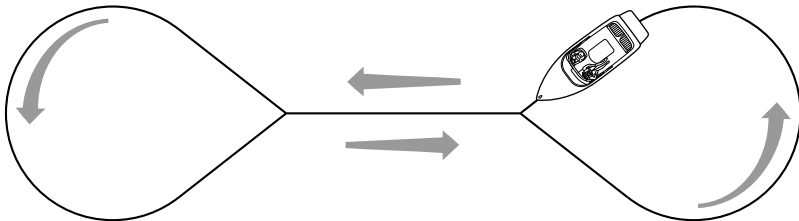

Dumb Bell Ski Pattern



Freezing Temperatures

When the boat is removed from the water, drain the cooling and heater system (as equipped) completely.

Anchoring

There are many types of anchors available on the market. The choice of one anchor over another depends on many factors. An anchor will usually hold best in a mixture of mud and clay or in hard sand. A Danforth anchor is recommended for general boating. For more information on anchors, contact your Nautique dealer.



WARNING

Improper use of an anchor can pull a boat underwater, causing death or serious injury. Anchor from the bow, NOT from the stern.



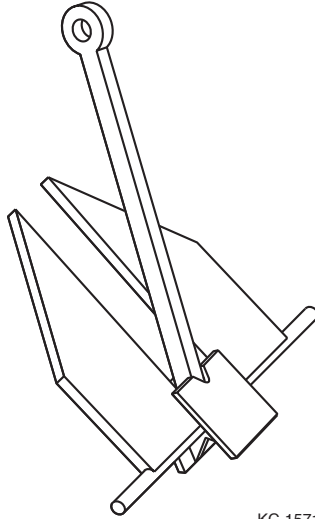

KC-1571C

Danforth Anchor

Dropping Anchor

- Make sure the line is tied to the anchor and tie the other end to the forward cleat or bow eye.
- Head the boat into the wind or current over the spot where you want to lower the anchor. Spot the boat before lowering the anchor.
- When the anchor hits bottom, slowly back up the boat, keeping tension on the line. Let out an anchor line that is six to seven times the depth of the water. For example, if you are in 10 feet (3 m) of water, let out 60 to 70 feet (18 to 21 meters) of line.



**LINE SIX TO SEVEN
TIMES DEPTH OF WATER**

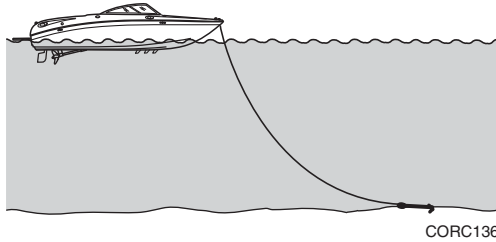

Anchoring

- Pull on the line to make sure the anchor is holding.
- Occasionally check your position against the shoreline. If the anchor is dragging and you are drifting, reset the anchor.

Weighing (Pulling In) Anchor

Start the engine and move forward until the anchor line is straight up and down. Pull hard to lift the anchor from the bottom material.

If the anchor is caught on the bottom, attach a line to the bow cleat so that it is taut. The up and down motion of the bow from wave action may lift the anchor from the bottom. If the anchor remains caught, let out a few more feet of line and attach it to the bow cleat. Slowly maneuver the boat around the anchor until the anchor pulls loose. Be sure to keep the line tight during this procedure.



Performance Boating



WARNING

Failure to maintain control can result in death or serious injury. Always keep one hand on the steering wheel and the other on the control lever. If the boat begins to operate in an unsafe way, adjust speed and course as necessary to regain control.

Your Nautique boat is a high performance boat. DO NOT be tempted to push your boat to its limits until you are completely familiar with its operating characteristics.

Nautique boats are the ones of choice of the better professional and amateur ski shows and tournaments. You may have seen drivers put their Nautique through extreme maneuvers. These drivers are paid professionals on a closed course with hundreds of hours of experience. DO NOT attempt extreme maneuvers without proper training.

We recommend that you never operate the boat without first having an initial orientation and familiarization/demonstration ride with your dealer or an operator experienced with the boat/engine combination. All boats perform differently.

The operator should have at least ten hours of experience with the boat before any full throttle operation. DO NOT operate your boat until you are completely experienced with its handling characteristics.

Propellers

Your Nautique boat is equipped with a propeller best matched to its engine and boat combination. If you feel you are experiencing poor performance, contact your Nautique dealer. Care and selection of your propeller is very important to proper boat operation.



NOTES





Section 8

Care and Maintenance

This section describes how to care and maintain your Nautique boat. Periodic inspection and maintenance of items listed in this section is absolutely necessary.

Winterization and some engine maintenance functions are best performed by your Nautique dealer. Some maintenance items that can be done by you or your dealer are listed below. We suggest that you familiarize yourself with these even if you have your dealer service your boat.

General Maintenance

1. Read engine operator and maintenance manual very carefully.
2. Check for fuel line leaks every time you use the boat.
3. **DO NOT** start your engine if gasoline odor is present. Gasoline fumes are highly explosive. Before starting your engine, open the engine cover, inspect the engine compartment for gasoline fumes and operate the blower for at least four minutes. Run your blower when operating at slow speeds. If fuel vapors are present, do not start the engine. Check all hoses and fittings to determine the source of the vapor. Make the necessary adjustments or take the boat to your local dealer to eliminate the fuel vapor.



WARNING

Fumes accumulating in bilge area present a fire or explosion hazard which could cause death or severe injury. Ventilate the engine compartment by running the blower for four minutes, especially after repairing or refueling and check for fuel spills or leaks. If you smell gasoline vapor or see liquid gasoline, DO NOT start the engine.

Section 8

4. When servicing the ignition switch or any wiring, always disconnect the battery cables from the battery.
5. Check for water circulation when the engine is running. Exhaust should contain steady flow of water. In closed cooling systems, make sure the coolant in the cooling system is at the proper level.

Engine Intake Water Strainer

Visually inspect the engine intake water strainer for debris before each use. To clean the strainer, close the engine intake water valve and unscrew the strainer bowl (A). DO NOT lose the rubber O-ring (B) that seals the bowl to the cap. Carefully remove the screen (C).

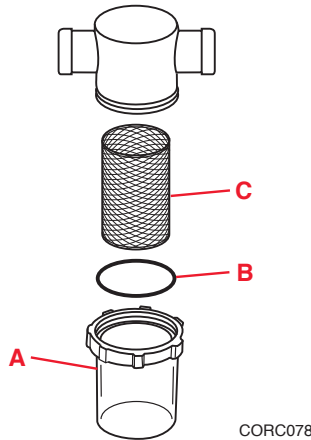
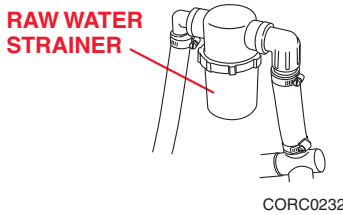

Care and Maintenance

Clean debris from the bowl and screen and rinse parts in fresh water. Insert the screen, place the O-ring in the groove of the bowl and screw the bowl on hand tight. Be sure to open the water valve before starting the engine.

Some engines are equipped with a closed cooling system with a self-contained reservoir for engine coolant. Self-contained systems are equipped with a heat exchanger which uses raw water to cool the coolant. All raw water systems are equipped with a valve and strainer.

Bilge Pumps

Check your bilge pumps often to make sure they are operating efficiently. There are two bilge pumps: one is at the rear of the boat near the rudder and under the floor by the forward bulkhead located next to the fuel tank. To keep the pumps from getting clogged, remove any debris you find in the bilge. Wash the bilge with a good biodegradable household detergent or a bilge cleaner available at your Nautique dealer or a marine supply store. Rinse with water with your bilge pumps running. If your pumps seem to lag, remove the top of the pump from the base and check the impeller to make sure there is no debris inside. See your dealer if there is still a problem with the pumps.



CE Bilge Discharge Filter

Your boat may be equipped with a CE-compliant bilge discharge filter system that is designed to prevent oil-contaminated bilge from being discharged into the environment. One CE bilge filter is required for each bilge pump. The CE bilge filter is located below the deck, connected to the bilge discharge hose just before the hose connection to the deck outlet fitting.

CE bilge discharge filter cartridge XOil™ replacement should be part of a regular maintenance program to prevent oily, contaminated bilge from passing through the deck outlet fitting into the environment. The period between cartridge replacements will depend on the condition of the bilge. Always replace the cartridge immediately after there has been a great amount of oil or other contaminants spilled into the bilge.

Cartridge Replacement

1. Turn off power to the bilge pump.
2. Unscrew the filter bowl (A) by turning counterclockwise and pour any excess bilge water remaining in the bowl back into the bilge.
3. Remove the used cartridge (B) and dispose of in a suitable container.
4. Inspect the O-ring (C) located on top of the bowl and replace if worn.
5. Be sure that the seals located on the top and bottom of new cartridge are in place and correctly aligned.
6. Place the new cartridge into the bowl and reattach the bowl to the filter housing (D) by turning clockwise.
7. Turn on power to the bilge pump.
8. Turn on the bilge pump and inspect all connections for leaks.
9. Bleed any air trapped in the housing by using the bleed button (F) or, if so equipped, the bleed screw (E). Both are located on top of the filter housing.

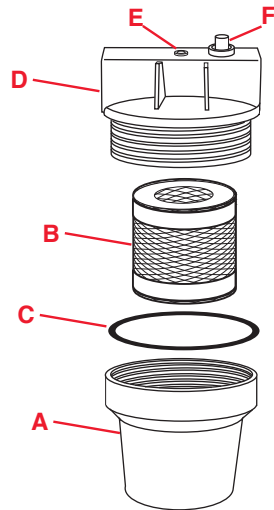

CORC0241

Propeller

CAUTION

- A propeller can be very sharp. Be careful when you handle it. Wear a pair of protective gloves when handling any propeller.
- Remove your key from the ignition and remove the emergency stop switch clip from the switch to prevent accidental starting of the engine.
- DO NOT reuse the nylon locknut or the cotter pin.
- DO NOT use a damaged propeller. A damaged propeller can damage your engine and boat.

Removal

1. Remove the cotter pin from the propeller shaft and discard.
2. Wedge a piece of 1" x 4" wood between the propeller blade and the starboard side of the strut and rudder.
3. Remove the nylon locknut and discard.



Section 8

Use a propeller puller to remove the propeller, then remove the key from the keyway. Inspect the keyways and key for any damage.

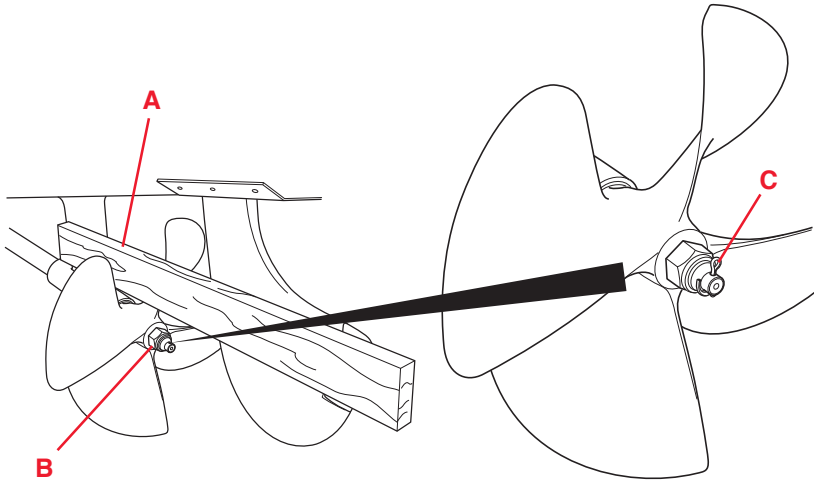

CORC047

Installation

Before placing the propeller on the shaft, look at the keyway on the shaft and in the propeller. Make sure the key slides freely in the shaft keyway and the propeller keyway. **DO NOT** use the propeller to advance the prop onto shaft.

If the key has burrs, remove them by filing the flat sides or replace the key. **DO NOT** file the key beyond its normal shape or size.

1. Rotate the shaft until the keyway is “up.”
2. Place the key in the shaft keyway. The propeller will only slip on in one direction. Rotate the propeller so the keyway in the propeller is aligned with the keyway on the shaft. Once it is aligned, push the propeller onto the shaft. You’ll hear a solid “thunk” or feel it, as the propeller is seated.
3. Wedge a piece of 1" x 4" wood (A) between the propeller blade and the port side of the strut and rudder.
4. Install a new nylon locknut (B) and torque the nut to maximum of 30 ft-lbs (40.7 N•m).
5. Install new cotter pin (C). Bend the retaining ends of the cotter pin in the opposite directions.

Propeller Shaft Stuffing Box

The stuffing box is designed to prevent water from coming through the through-hull fittings. These are found on the propeller shaft where the shaft goes through the hull and where the rudder comes up through the bottom of the boat. These devices contain a lubricated fibrous packing that acts as a seal.

Check the propeller shaft stuffing box frequently for excessive leakage. The engine must be off. A leaking rate of a few drops per minute is acceptable and expected for proper lubrication. Raise the engine cover and remove the storage bulkheads. If you see a steady stream of water or an excessive drip rate, return your boat to your Nautique dealer for service.

Through-Hull Fittings

All fittings that actually pass through the hull on the wetted surface are caulked in. These are not serviceable and must not be tampered with.

Quick Oil Drain System

Change the engine oil after the first 25 hours of operation, then after every 50 hours. The boat must be removed from the water to use the quick oil drain system. There is a drain hose attached to the bottom of the oil pan with a small plug screwed into the loose end of the hose. Remove the drain plug (T-handle), located in the bilge area, and put the end of the drain hose through the drain hole.

Make sure there are no kinks or sharp bends in the hose. Remove the plug at the end of the hose and drain the oil into a container under the boat. The engine will drain most efficiently when the oil is warm. Allow several minutes for the oil to settle and drain. Dispose of used oil in an environmentally safe manner.

NOTICE

Be sure the engine is off when you are draining your oil.



WARNING

Prolonged or repeated contact of used engine oil can cause death or serious injury. Wash affected area immediately with soap and water.



Salt Water Boating

NOTICE

If you use your boat in salt water or other unusual water conditions, fresh water flush your engine and cooling system with freshwater.

Nautique offers an optional fresh water flush kit. This is the only system we recommend if you use your boat in salt water or unusual water conditions. Flushing the system by running the boat in fresh water is another good way to flush the engine, but it must be done immediately.

Freshwater Flushing Kit-Optional

The optional freshwater flushing kit allows you to flush the water system after your boat is operated in salt water, brackish water or unusual water conditions.

We recommend using this system if you use your boat in salt water or unusual water conditions. Flushing the system by running the boat in fresh water is another good way to flush the engine, but it must be done immediately.

DO NOT connect the flushing kit to a water source which exceeds normal municipality water pressure.

Proper Use of Freshwater Flushing Kit

1. Open the ball valve located between the system's deck fitting and main engine cooling water supply hose.
2. Make sure that the ball valve located in the main cooling system supply hose is open. This valve is located near the hull inlet fitting.
3. Open the cap of the system deck fitting and properly connect a water supply hose, making sure the connection is secure.
4. Turn on the hose and start the engine.



Care and Maintenance

5. Close the ball valve of step 2 unless the boat is on a trailer or lifted up in the air, in which case it should be left open.
6. Run the engine for several minutes after it has reached the normal operating temperature to ensure proper flushing.
7. Reduce the engine speed to idle, shut off the engine and immediately shut off the water supply hose. Please note, failure to shut off the water supply hose immediately could possibly result in engine damage.
8. If the ball valve of step 5 was closed, open it now and close the step 1 ball valve.
9. Remove the water supply hose and reinstall the deck fitting cap securely.

Battery Maintenance



WARNING

Explosion or fire hazard from vented fumes can cause death or serious injury.

- **Wear eye protection and rubber gloves when working on or around batteries.**
- **DO NOT charge or use a battery booster to start your engine.**
- **Charge the battery outside of the boat.**
- **DO NOT smoke or bring a flame near a battery at any time.**
- **DO NOT have your head directly above a battery when making or breaking electrical connections.**
- **DO NOT use a metal object to spark between battery posts to check if the battery is charged.**

Take care when connecting or disconnecting a battery charger. Be sure the charger is turned off and unplugged from power source when you clip on/off the connecting clamps.

Make sure you have a solid connection with the charging clamps. Poor connections are common causes of electrical arcs and engine problems. Follow instructions.



Section 8

DO NOT make or break electrical circuits at the battery terminals; a spark will occur when a live circuit is opened or made. Turn off all components.

Use a voltmeter or hydrometer to check the battery charge condition.

The battery cables should be removed from the battery when the boat is placed in storage, on display or in transit. This will eliminate the possibility of the engine accidentally starting without a supply of cooling water and may damage the engine.

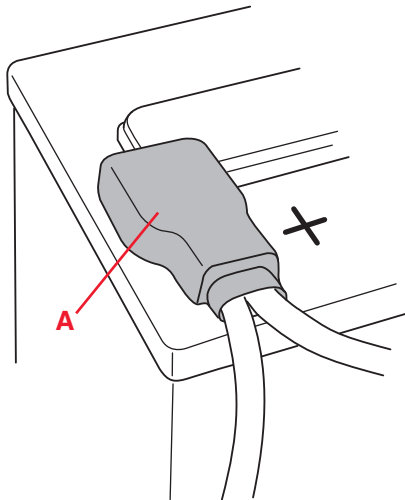

CORC212

+ = red positive (A)

- = black negative (not shown)

To clean your battery, remove and wash down the battery case with a diluted ammonia or baking soda/water solution to neutralize the acid, then flush with fresh water. Keep the fill/vent caps tight so the neutralizing solution does not get into the battery cells.

The electrolyte level should be checked every 30 days. Add only distilled water to maintain the level between the top of the plates and the bottom of the fill/vent cap. DO NOT overfill. Remember batteries contain sulfuric acid which can cause severe burns.

Gelcoat Maintenance

Your Skipper's Kit included samples of quality boat care products recommended by Nautique. Nautique is proud of its heritage and wants you to feel this pride every time you use your boat.

Regular maintenance is the key to keeping your hull and deck surfaces in good condition. Sun exposure, residue from trees and minerals in the water affect your boat's finish.

To help maintain the shine of your boat, wash the hull with a mild bio-degradable detergent after each use. This will help to remove any debris and waterborne materials that are on the hull. Use a soft sponge or towel and dry with a chamois cloth to prevent water spots.

Wax the hull sides and deck regularly with a high-quality wax. Waxes and polishes are available at your Nautique dealer and marine supply stores. Always follow the directions on these products carefully before you use them.

The hull bottom is an especially important area to keep clean since any buildup of water scum and algae will create drag and reduce the boat's efficiency. If you must leave your boat in the water, there are compounds to remove algae buildup on your hull. Some of these can be caustic. Pay special attention to the cautions on the label of these coatings. Ask your Nautique dealer for advice on which work best in your area.

If your boat's gelcoat develops a chalky look over a period of time due to exposure to sun, there are gelcoat buffing and polishing compounds available at your Nautique dealer and marine supply stores. **DO NOT** use common household scouring pads or powders.

If you will be keeping your boat in the water for ANY period of time, we suggest that the wetted surface of the hull be painted with an epoxy paint formulated for blister protection.



Section 8

Sudden changes in temperature can affect gelcoat. If you move your boat from outdoors to a heated area, allow the temperature change to be gradual. Heat the area after the boat is moved to allow the boat to warm up slowly as the area is heated. Also, if you move your boat from a warmer area to a colder one, wait for the outside temperature to be closer to the warmer area's temperature or allow the area and the boat to cool down first.

Care of Metal

- Aluminum care
- Stainless care
- Chrome
- Anodized towers
- Aluminum Clear Coat Towers

Keep all metal work rinsed and wiped dry. Periodically polish it with a quality commercially available metal polish to remove substances such as airborne pollution and natural body oils from your hands. Do not use citrus cleaners on stainless steel or wax on anodized towers. For best results on the aluminum clear coat towers, use cleaners and waxes suitable for clear coat finishes.

Care of Glass

Your windshield, mirrors and gauge faces all deserve the same attention as the other parts of your boat. Clean them often with quality commercially available glass cleaners.



Vinyl Maintenance and Cleaning

Nautique has selected the finest marine grade vinyl for your Nautique. It is important to keep it clean at all times. There are some substances that will stain the vinyl if you leave them on for even a short period of time. Remove any contaminant and clean the area immediately. **DO NOT** use Formula 409® Cleaner, Fantastik® or any silicone-based products. Certain household cleaners, powdered abrasives, steel wool, industrial cleaners, dry cleaning fluids and lacquer solvents can cause damage and discoloration. **DO NOT** use these cleaners.



Section 8

Common stains and steps to treat:

	Step #1	Step #2	Step #3
Chewing gum	D	A	D then A
Eye shadow	E	B	E then B
Engine oil	B	B	B
Spray paint	C	B	B
Mildew or wet leaves *	D	B	A
Shoe polish *	A	B	
Yellow mustard	D	B	
Oil based paint (fresh)	D	B	
Oil based paint (dried)	A	B	
Suntan lotion *	D	B	
Tar/Asphalt	A	B	
Lipstick	A	B	
Latex paint	A	B	
Crayon	D	B	
Ketchup	A	B	
Grease	D	B	
Ball-point ink *	E	B	
Permanent marker *	E	B	
Coffee, tea, chocolate	B	B	

Use the chart above to clean common stains:

- A. Medium-soft brush, warm, soapy water/rinse/dry
- B. Meguires Quick Clean #52
- C. One(1) tablespoon ammonia, 1/4 cup hydrogen peroxide, 3/4 cup water, rinse/dry
- D. Wipe or scrape off excess (chill gum with ice)
- E. Denatured Alcohol/rinse/dry

After all cleaning methods, rinse well with water.

*Suntan lotion, shoe polish, wet leaves and some other products contain dyes that stain permanently.



Tunable Rudder

The Tunable Rudder* is designed to offer easy steering adjustment. This system uses a composite tuning foil which is located at the upper aft corner of the rudder blade. Use a Phillips head screwdriver to adjust the foil. Loosen the two screws in the relief slots of the tuning foil.

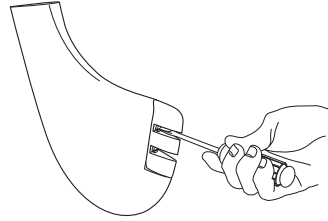

CORC045

If the boat is pulling port (**A**), rotate the foil to port (**B**) and tighten screws. If the boat is pulling starboard (**C**), rotate the foil to starboard (**D**) and tighten screws. Always remember that movement of the trailing edge of the foil to one side will cause the steering to pull to the opposite side.

NOTICE

After each adjustment, test run and adjust again if necessary.

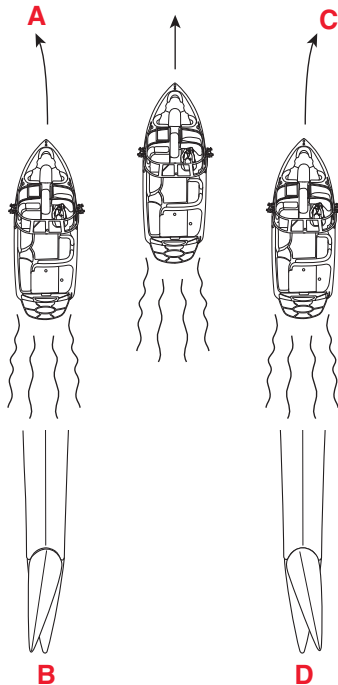

CORC162

*Manufactured under license from National Products, Inc. U.S. patent 5,746,147.



Section 8

Rudder Remote Lube Fitting

The remote lube fitting allows for easy access to lubricating the rudder. The remote lube fitting is located at the stern of the engine compartment. Use a quality marine grease and gun. Connect the grease gun to the fitting and apply a light pressure to the gun until you feel a slight resistance.



Transmission



WARNING

Burn hazard from hot transmission fluid can cause serious injury. Do not remove the transmission drain/fill plug while the engine is running or while the transmission is hot.

Allow the transmission to cool and check with the boat level.

1. Remove the drain/fill plug from the transmission.
2. Verify the fluid level; the fluid level should be at the bottom of the threaded hole. If low, add the specified fluid through the threaded hole to the proper level.

NOTICE

The transmission fluid is a very high viscosity; to make adding fluid easier, remove both fill plugs.

3. Replace the drain/fill plug and tighten securely.

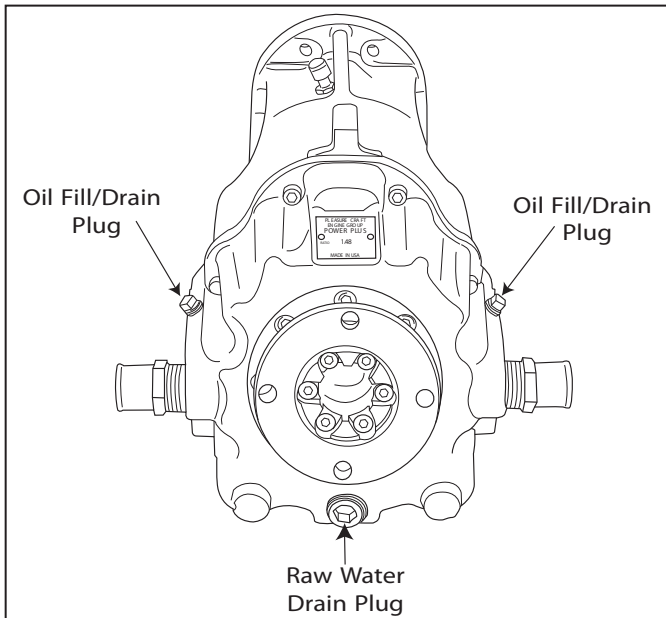

CORC210



Section 8

Shift Cable

Lubricate pivot points and exposed cable with SAE 30W-30 engine oil.

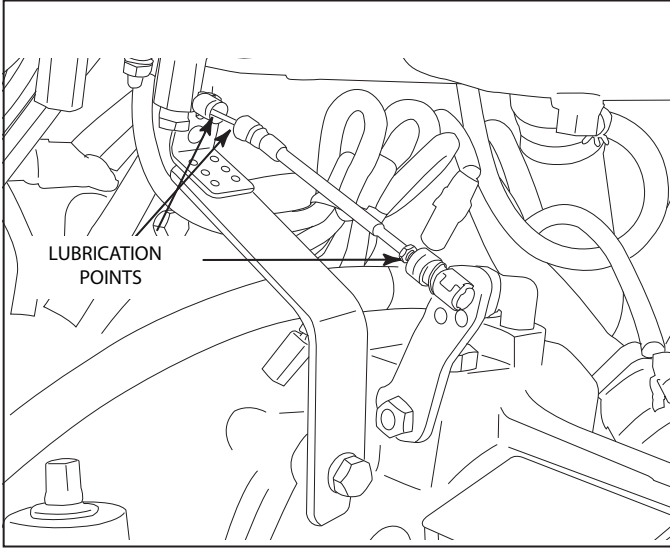

CORC211



Section 9

Troubleshooting

The following chart will assist you in finding and correcting minor problems with your Nautique boat. Refer to your engine operation and maintenance manual for more detailed information for any problem concerning the starting, shifting or operation of the engine.

Some problems may require the skills of a trained technician and special service tools. Please contact your Nautique dealer for assistance.

Section 9

Trouble Check Chart

Performance

Symptom	Possible Cause
Starter motor will not operate	• Shift handle not in NEUTRAL
	• Battery Selector switch off
	• Battery and electrical connection loose or corroded
Engine will not start	• Emergency stop switch not in place
	• Starting procedure not followed
	• Fuel tank empty
Poor boat performance	• Contaminated fuel
	• Clogged fuel filter
	• Uneven load distribution
	• Improper propeller selection
	• Marine growth on hull
	• Engine problem
Poor gas mileage	• Marine growth on hull
	• Engine problem
Excessive vibration	• Damaged or fouled propeller
	• Misaligned propeller shaft coupling
	• Bent propeller shaft
	• Engine problem
Engine runs but boat makes little or no progress	• Fouled or damaged propeller
	• Engine problem
Steering problem	• Corroded steering cable
	• Rudder worn
Throttle/shifting problems	• Corroded cables
	• Defective throttle return spring
	• Low transmission fluid level
	• Sticking transmission shift lever



Troubleshooting

Electrical

Symptom	Possible Cause
Electrical problem	• Open circuit breaker or blown fuse
	• Loose wiring connection
	• Defective switch or gauge
Dim or no lights	• Open circuit breaker tripped or in OFF position
	• Battery discharged
	• See Page 4-32



NOTES





Section 10 Storage

Lifting Rings and Lifting Eyes

Your Nautique has a bow lifting ring and stern lifting eyes. These are designed to lift your boat in a steady and secure manner. The winch, hooks and other components of the lifting mechanism have sufficient capacity sufficient for your boat. Refer to Section 3, Specifications. The weights listed in the specifications are dry weight. You must add the weight of the battery, fuel and gear to the dry weight.

If the lifting eyes at the stern of the boat are below the boarding platform, the platform **MUST BE** removed before the boat is lifted. The platform **MUST BE** reinstalled before the boat is put back into service.

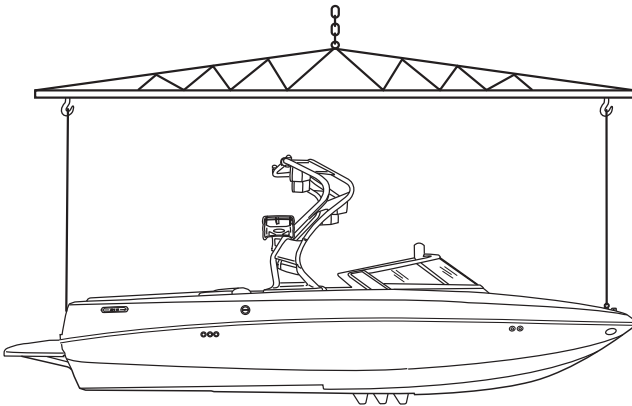

CORC0240

Section 10

CAUTION

Drain the bilge and / or launch control system and/or aftermarket water bladder(s) to eliminate excess water before you lift the boat.

NOTICE

Only use a hook that will pass easily through the lifting rings or eyes without binding. A hook that is too large or off-center could break the lifting rings or eyes. DO NOT use a sling to lift the boat. Damage to your boat can occur.

If your boat is equipped with a retractable lifting eye, it can be used for lifting your boat.

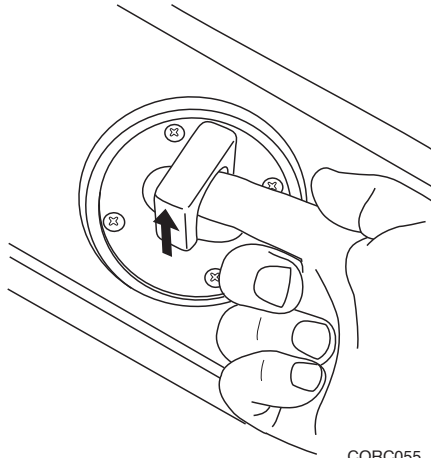

Winterizing Your Boat

Winter storage procedures vary depending on climate, type of storage and length of storage. Check with your dealer/storage facility manager for their advice on what works best in your climate. Winterization functions are best performed by your Nautique dealer. Refer to your engine operation and maintenance manual for more information.

When storing your boat up on a rack system, it is important the racks adequately support the hull bottom.

If you do not have a trailer, support the boat like a Nautique dealer recommended trailer. It is important to have an even weight distribution.

If you do not have a dealer or marina nearby and must arrange winter storage yourself, contact your regional warehouse.

If you use a mooring cover, **DO NOT** put it on when the interior of the boat is wet and/or hot. It will trap moisture and lead to mildew on the carpet and/or vinyl. Make sure your mooring cover allows air to circulate, even if you have to leave a portion of the cover off.

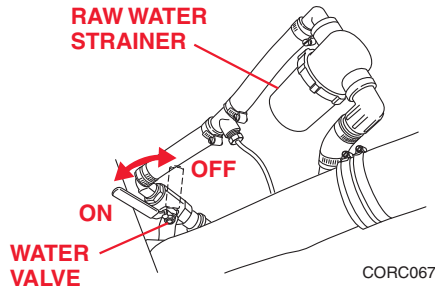

Section 10

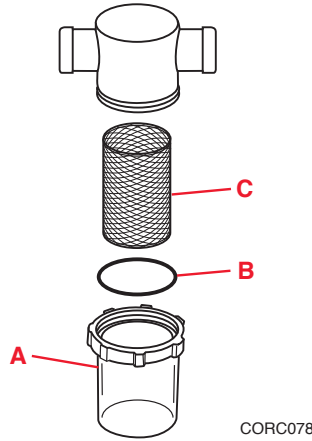

The raw water strainer bowl (A) remains full of water even after the rest of the engine cooling water system is drained. To properly winterize your boat, the strainer bowl must be removed and emptied. **DO NOT lose the rubber O-ring (B) that seals the bowl to the cap.** Clean screen (C) if required. If the water is not removed, the bowl can be damaged. A damaged strainer can cause overheating problems during the next season.



Check for Water in Your Fuel System

A small amount of water left in the fuel system for several months can result in damage to the fuel system and engine. If you are storing your boat for the winter, it is a good practice to remove any water in the fuel system.

The fuel control cell can be drained by removing the drain plug at the bottom of the canister.

1. Loosen the return fuel hose to provide an incoming air source.
2. Clamp the return fuel line some way to minimize the amount of fuel that may drain.
3. Once the canister is drained, coat the threads of the drain plug with a fuel resistant pipe thread sealer, then replace and tighten the plug.
4. Reconnect the fuel hose, and tighten the hose clamp. The threads must be sealed properly to avoid a possible fuel leak.

Check your fuel control cell once each year for signs of water in the canister. If it appears there is water buildup in the canister, see your Nautique dealer for service.

An empty fuel tank can accumulate water inside by changing temperature and repeated cycles of condensation on the inner surfaces of the tank. If the fuel tank is kept at about 3/4 full during storage, less water can condense, limiting the buildup of water in the fuel tank.

Fill the tank to 3/4 full maximum during storage to eliminate the possibility of fuel expansion problems caused by temperature changes. This minimizes overflow of fuel from the fuel vent. Not only can this overflow be hazardous, but it will also adversely affect decals and pin striping on the boat.



Section 10

Add a good quality fuel stabilizer to the fuel prior to winterizing to slow down the rate of fuel decomposition. You can purchase a fuel stabilizer at your servicing dealer, most marinas or an auto supply store. Add the stabilizer to the tank.

If you did not add the stabilizer previously, run the engine to circulate fuel throughout the system. Remember, always follow the fuel stabilizer manufacturer's recommendations for proper mixing.

NOTICE

Gasoline expands when the temperature increases. Never store your boat with more than 3/4 of a tank.

Refer to the engine's owner's manual for winterization of the engine.

Winterizing Ballast Tanks (if equipped)

NOTICE

It is extremely important to protect the Flight Control System during freezing temperatures and during long periods of non-use. When following this procedure, remember to protect our natural resources by using environmentally friendly products and to always discard in an environmentally friendly manner.

1. Make sure your boat is out of the water, the tanks are completely drained and the tank water intake/drain valves are open.
2. Use a 50/50 mixture of an environmentally friendly antifreeze and fresh water.
3. Pour an even amount, approximately 1 gallon (3.8 liters), of the antifreeze mixture into each tank's vent.
4. Place a container under the intake/drain of the tank you are winterizing to catch any spilled mixture.
5. Operate the pump in the drain mode for two seconds and shut off. Repeat procedure for other tank(s).
6. Close the tank's water intake/drain valves.

When returning your boat back to service, drain the remainder of the mixture before getting onto the water.



Trailer/Trailerling

Hitch

If you do not already have a trailer hitch installed on your vehicle, go to a reputable hitch company to have the proper size hitch installed. Always use a hitch rated with the appropriate capacity to match the trailer and boat's gross weight.



WARNING

Loss of control can cause death or serious injury. DO NOT attempt to tow more than one trailer at a time behind your vehicle. Attempting to tow an additional trailer will adversely affect the trailer tongue weight.

CAUTION

DO NOT use a bumper mounted hitch on your vehicle. Use a hitch that is attached to the frame of your vehicle only. DO NOT compromise your equipment, your safety or the safety of others.

Wiring

The trailer requires wiring from your vehicle to the trailer lights. This can usually be done by the hitch company.

Security

There are several locking devices available at marine supply stores to aid in securing your boat whether or not it is attached to your vehicle.



Section 10

Towing Your Boat

Read this checklist prior to trailering your boat.

- Check wheel lug nuts for tightness.
- Be sure the trailer tongue is securely on the hitch and the safety chains from the trailer are secured to the vehicle.
- If your boat is equipped with a trailer bow winch, make sure the boat is properly located on the trailer and the winch strap/cable is tight.
- Be sure a cable or strap secures the bow eye of the boat to the trailer. Make sure this is tightly secured.
- Be sure the trailer electrical connector is plugged in. Allow sufficient slack for cornering. Check brake lights, turn signals, emergency flasher and running lights.
- Be sure your gear inside the boat and seat cushions cannot shift or fly out of the boat during trailering.
- Be sure the walk-thru door of the windshield is closed and latched while the boat is being trailered.
- If you are using any sort of water “ballast” system to add weight to the boat, be sure it is drained before you put the boat on the trailer. These systems can adversely affect the tongue weight of the trailer. Your boat is not designed to carry exceptionally heavy loads. This can adversely affect the proper balance of the boat/trailer combination and cause tire failure and/or loss of control.
- Make sure the platform bracket pins are in place before trailering.
- Remove bilge drain plug(s).



Long Trips

DO NOT use your boat and trailer to haul excessive gear.

Each time you stop on a long trip, check the following:

- Make sure the wheel lug nuts are tight and the bearings are lubricated.
- Make sure the boat is still positioned snugly against the bow stops and has not shifted.
- Examine the hitch connection to be sure it is firmly attached and the safety pin and chains are securely fastened.
- Make sure all trailer lights are still functioning properly.
- Reexamine the contents of your boat to ensure that no items such as life jackets or other gear have shifted and will not fly out while you are on the road.



Section 10

NOTES





Glossary

ABYC – American Boat and Yacht Council, Inc.

AFLOAT – On the water.

AFT – Toward the rear or stern of the boat.

AGROUND – Touching bottom.

AMIDSHIP – Center or middle of the boat.

ANCHOR – (1) An iron casting shaped to grip the lake bottom to hold the boat. (2) The act of setting the anchor.

ANODE – An electrode carrying a positive charge.

ASHORE – On the shore.

ASTERN – Toward the stern.

BAIL – To remove water from the bottom of the boat with a pump, bucket, sponge, etc.

BALLAST – Any solid or liquid weight placed in a boat to increase the draft, to change the trim.

BEAM – The widest point on the boat.

BEARING – Relative position or direction of an object from the boat.

BILGE – The lowest interior section of the boat hull.

BOARDING – To enter the boat.

BOUNDARY WATERS – A body of water between two areas of jurisdiction; i.e., a river between two states.

BOW – The forward end of the boat.

BULKHEAD – Vertical partition (wall) in a boat.

BUNKS – Carpeted trailer hull supports.

BURDENED BOAT – Term for the boat that must "give-way" to boats with the right-of-way.

CAPACITY PLATE – A plate that provides maximum weight capacity and engine horsepower rating information. It is located in full view of the helm.

CAPSIZE – To turn over.

CAST-OFF – To unfasten mooring lines in preparation for departure.

CATHODE – An electrode carrying a negative charge.

CAVITATION – A phenomenon in which low pressure within a liquid allows vapor bubbles to form.

CENTER LINE – A lengthwise imaginary line which runs fore and aft with the boat's keel.

CHINE – The point on a boat where the side intersects (meets) the bottom.

CLEAT – A deck fitting with ears to which lines are fastened.

CONSOLE – Also called helm. The steering wheel area of the boat.

CRANKING BATTERY – The main battery used for engine starting and electrical circuits.

CURRENT – Water moving in a horizontal direction.

DEADRISE – Transverse angle of the bottom of the hull.

DECK – The open surface on the boat where the passengers walk.

DRAFT – The depth of the boat below the water line, measured vertically to the lowest part of the hull.

ELECTROLYSIS – The break-up of metals due to the effects of galvanic corrosion.

FENDER – Devices built into or hung over the sides of a boat to prevent the boat from rubbing or chafing against other boats or piers.

FORE – Toward the front or bow of the boat. Opposite of aft.

FREEBOARD – The distance from the waterline to the upper surface of the side of the deck.

FUEL SENDING UNIT – The electrical device that is mounted on the outside of a built-in fuel tank and controls the dashboard fuel gauge.

GIVE-WAY BOAT – (1) Term for the boat that must take whatever action necessary to keep well clear of the boat with the right-of-way in meeting or crossing situations. (2) The burdened boat.

GUNWALE – The rail or upper edge of a boat's side.

HEAD – A marine toilet.

HELM – The steering wheel or command area.

HULL – The structural body of a boat below the deck.



HYPOTHERMIA – A physical condition where the body loses heat faster than it can produce it.

IN-LINE FUSE – A type of protective fuse located in the power wire of a direct current (DC) circuit usually near the battery.

KEEL – The lowest portion of the boat; extends fore and aft along the boat's bottom.

LINE – All rope in a boat or on the dock is referred to as "line."

LIST – Leaning or tilt of a boat toward the side.

MAKING WAY – Making progress through the water.

MARINE CHART – Seagoing maps showing depths, buoys, navigation aids, etc.

MID SHIP (AMIDSHIP) – In the vicinity of the mid-length of a boat, technically the exact half way between the bow and the stern.

MOORING – An anchor, chain, or similar device that holds a boat in one location.

NAVIGATION AID – Recognizable objects on land or sea such as buoys, towers or lights which are used to fix position to identify safe and unsafe waters.

NMMA – National Marine Manufacturer's Association

NO-WAKE SPEED – The speed at which a boat travels to produce an inperceptible wake.

PFD – Personal flotation device.

PITOT TUBE – See SPEEDOMETER PICKUP TUBE.

PLANING HULL – A hull designed to lift, thereby reducing friction and increasing efficiency.

PORPOISE – A condition in which the bow bounces up and down caused by trimming the engine too far out.

PORT – (1) The left side of a boat when facing the bow. (2) A destination or harbor.

PRIVILEGED BOAT – Term used for the boat with the right-of-way.

PROPELLER PITCH – Theoretical linear distance the propeller would move ahead during one complete revolution of it were turning with zero slippage.

RIGHT-OF-WAY – Term for the boat that has priority in meeting or crossing situations. The stand on or privileged boat.

RUB RAIL – The rubber extrusion that is fastened over the hull and deck joint.



RUDDER – A vertical metal device used to steer the boat

RULES OF THE ROAD – Regulations for preventing collisions on the water.

SACRIFICIAL ANODE – Metal parts fitted to the hull of boat to provide a transfer of ions to the cathodic part of an electrolytic coupling and so protect other parts of the boat that would otherwise waste away through electrolysis

SLIP – The linear distance between the pitch (or advance) and the actual distance the propeller moves straight ahead through the water.

SPEEDOMETER PICKUP TUBE – Also called pitot tube. The plastic device that extends below the bottom of the boat. It connects to the speedometer with plastic flexible tubing.

SPRING LINE – A mooring rope oriented at a small angle to the boat's centerline, usually attached to the boat mid ship.

STAND ON BOAT – Term for the boat that must maintain course and speed in meeting or crossing situations. The privileged boat.

STARBOARD – The right side of the boat when looking towards the bow.

STERN – The aft end of a boat.

STOW – To put away. To store cargo in a storage locker.

STRINGER – Members under the floor that stiffen the hull bottom.

SURGE BRAKES – A type of trailer braking system designed to automatically actuate when the tow vehicle's brakes are applied.

TRANSDUCER – The unit that sends/receives signals for the depth sounder.

TRANSOM – The transverse beam across the stern.

TRIM – Fore to aft and side to side balance of the boat when loaded.

UNDERWAY – Boat in motion; i.e., not moored or anchored.

USCG – United States Coast Guard

VISUAL DISTRESS SIGNAL – A device used to signal the need for assistance such as flags, lights and flares.

WAKE – The waves that a boat leaves behind when moving through the water.

WATERLINE – The line of the water's edge when the boat is afloat.

WATERWAY – A navigable body of water.

WETTED SURFACE – The area of the immersed hull plus underwater gear.





Warranty

CORRECT CRAFT LIMITED WARRANTY

(Boats as Originally Manufactured by Correct Craft)

The Correct Craft warranty is backed by a family tradition of boat building experience since 1925.

Lifetime Limited Warranty:

Correct Craft, Inc. warrants to the original user or purchaser, whoever comes first, of each new Nautique boat, that the deck, hull, and stringer system as originally manufactured by Correct Craft, shall under normal authorized use remain free from structural defect in material and workmanship.

Transferable Lifetime Limited Warranty:

In addition, Correct Craft offers a Transferable Lifetime Limited Warranty against structural defect of the deck, hull and stringer system as detailed in the Lifetime Limited Warranty above. This policy may be transferred for a nominal fee to the second (2nd) purchaser during a period of five (5) years from the date of delivery to the original user or purchaser. See owner's manual for proper form.

Exception: The "Lifetime" and "Transferable" warranties do not cover the gelcoat nor any other components fastened or applied to the hull or deck. Gelcoat discoloration, blisters, or bubbles and cracks are not considered structural defects.

Boat Five (5) Year Transferable Limited Warranty:

Correct Craft, Inc. warrants to the original user or purchaser, whichever comes first, that each new Nautique boat, as **originally manufactured by Correct Craft**, shall under normal authorized use be free of defect in material and workmanship for a period of five (5) years from the date of delivery. This coverage applies to **factory-installed components** including V-drive, boat parts, options, or other components not manufactured by Correct Craft, Inc. The remaining portion of this warranty covering **PARTS** (no labor), may be transferred for a nominal fee to the second (2nd) purchaser during a period of five (5) years from the date of delivery. See owner's manual for proper form.

Gelcoat Three (3) Year Non-transferable Limited Warranty:

Correct Craft, Inc. warrants to the original user or purchaser, whichever comes first, of each new Nautique boat that the gelcoat, under normal authorized use, shall remain free from defect in material and workmanship (including blisters and cracks not caused by negligence, impact or collision) for a period of three (3) years from date of delivery. NOTE: Gelcoat maintenance is the owner's responsibility.

Engine Warranty:

For details see Pleasurecraft Marine Engine Co., owner's manual.

Exceptions: This "Correct Craft Limited Warranty" shall not apply to...

- Any Nautique boat which has been used at any time for commercial or racing purposes, as a demonstrator or in a promotional program, ski school or ski show.
- Normal maintenance of boat, or any component thereof, including but not limited to alignment, adjustments, connectors, saltwater/brackish water corrosion, and wear items including, but not limited to, non-skid material, battery, bushings, packing material, bulbs, seals, gaskets.
- Gelcoat finish or colorfastness of gelcoat finish, chrome plated, anodized or aluminum finish or colorfastness of finish.



Warranty

- Damage or malfunction of a boat, or any component thereof, resulting from owner use, lack of maintenance, improper maintenance, impact, misuse, negligence, collision, delay of repair (unless specifically and directly authorized by the Correct Craft warranty department in writing), trailer or trailer design, improper or inadequate trailering or cradling of the boat.
- Any addition, modification or repair of the boat, or any component thereof, caused by, resulting from or in connection with any party other than Correct Craft, Inc., or any defect or product failure caused by, resulting from or in connection with any such addition, modification or repair.
- **Any and all consequential damages including, but not limited to, costs incurred for haul-out, launching, towing, and storage charges, telephone or rental charges of any type, inconveniences, or loss of time or income.**

Any defect or damage covered by this warranty shall, at the discretion of Correct Craft, Inc., be repaired free of charge at an authorized dealership or service facility. Repairs will be warranted only for the remainder of the original warranty period. Transportation and/or labor to and from the point of repair will be the responsibility of the owner.

THERE ARE NO WARRANTIES WHICH EXTEND BEYOND THE DESCRIPTION OF THE FACE HEREOF. THIS LIMITED WARRANTY IS EXPRESSLY MADE IN LIEU OF ALL OTHER EXPRESSED WARRANTIES. DURATION OF ANY IMPLIED WARRANTY OF MERCHANTABILITY OR FITNESS FOR A PARTICULAR PURPOSE OR OTHERWISE, SHALL BE LIMITED TO AND COINCIDENT TO THE DURATION OF THESE EXPRESSED WARRANTIES. UNDER NO CIRCUMSTANCES SHALL CORRECT CRAFT, INC. BE LIABLE TO THE PURCHASER OR ANY THIRD PARTY FOR LOSS OF PROFITS OR OTHER DIRECT OR INDIRECT COSTS, LOSSES OR CONSEQUENTIAL DAMAGES ARISING OUT OF OR AS A RESULT OF DEFECTS IN PRODUCTS HEREIN ABOVE WARRANTED.



Some states do not allow limitations on how long an implied warranty lasts. Some states do not allow the exclusion or limitation of incidental or consequential damages. This warranty gives you specific legal rights, and you also have other rights which may vary from state to state. To the extent that your state does not allow any exclusion or limitation expressed herein, such exclusion or limitation will not apply to you. All other allowable limitations or exclusions shall apply to you.

Note: This warranty is expressly conditioned upon the completion and return of the warranty registration card to Correct Craft, Inc. Although not obligated to and without creating such an obligation, this will enable us to notify you of any necessary performance or safety modifications to your boat and to verify ownership in case a warranty claim is filed on your boat.

Procedure:

In the event your Nautique boat has a claim covered by this warranty, the following procedure shall be allowed to secure performance of warranty obligations:

1. **Notify the selling dealer in writing within thirty (30) days after the discovery of any claimed defect.**
2. You may be required to transport the boat, at your expense, to an authorized dealership or service facility for their inspection and/or repair.
3. Correct Craft, Inc. reserves the right to require further evaluation and/or information regarding a warranty claim against a boat prior to its repair as well as designate the place of repair.

Correct Craft, Inc. reserves the right to make changes in prices, color, specifications, equipment, options, materials, hull, decks, and/or discontinue models at any time (without notice), and shall be under no obligation to equip or modify boats built prior to such changes.

Correct Craft, Inc., 14700 Aerospace Pkwy, Orlando, Florida 32832. 407/855-4141, FAX 407/851-7844, E-mail address: info@nautiques.com. Effective 2006-2009 Model boats.





REQUEST FOR TRANSFER OF WARRANTY ON PARTS

**** A COPY OF THE PURCHASE RECEIPT MUST BE INCLUDED ****

At Correct Craft, Inc.'s discretion, the remaining portion of the Correct Craft Inc "Boat Five (5) Year Transferable Limited Warranty" of 2006-2009 model boats, that covers parts (no labor), can be transferred for \$300.00 to the second purchaser within five (5) years from the date of sale to the first purchaser. The sale must be complete within the first five years. The limited warranty on parts (no labor) will be transferred upon the receipt and verification of: (1) this completed form, (2) a copy of the purchase receipt, (3) a payment of \$300.00 to "Correct Craft, Inc". This data **MUST BE RECEIVED WITHIN 15 DAYS OF THE SALE DATE**. The warranty will be transferred retroactive to the sale date. Review the warranty policy for details.

NOTE: THIS TRANSFER DOES NOT INCLUDE THE ENGINE.

ORIGINAL OWNER _____

BOAT MODEL/TYPE _____

HULL NUMBER / CTC... _____

NEW OWNER INFORMATION:

NAME _____

STREET / P.O. BOX _____

CITY / STATE / ZIP CODE _____

DATE PURCHASED ___ / ___ / ___ PHONE NO. _____

THE CRITERIA LISTED ABOVE **MUST BE RECEIVED WITHIN 15 DAYS OF THE SALE DATE**. SUBMIT IT TO CORRECT CRAFT, INC., 14700 AEROSPACE PKWY, ORLANDO, FLORIDA 32832, "ATTENTION WARRANTY DEPARTMENT."

NOTE: Upon verification, the warranty will transfer retroactive to the sale date





**REQUEST FOR WARRANTY TRANSFER OF
HULL, DECK, AND STRINGER**

****A COPY OF THE PURCHASE RECEIPT MUST BE INCLUDED ****

At Correct Craft, Inc.'s discretion, Correct Craft's Lifetime Limited Warranty against structural defects in material and workmanship of the hull, deck, and stringer for 2006-2009 model boats can be transferred, for a nominal fee, to the second purchaser within five (5) years from the date of sale to the first purchaser. The sale must be complete within the first five years. The limited warranty will be transferred upon the receipt and verification of: (1) this completed form, (2) a copy of the purchase receipt, (3) a payment of \$300.00 to "Correct Craft, Inc". This data **MUST BE RECEIVED WITHIN 15 DAYS OF THE SALE DATE**. The warranty will be transferred retroactive to the sale date. Review the warranty policy for details.

NOTE: THIS TRANSFER DOES NOT INCLUDE THE ENGINE.

ORIGINAL OWNER _____

BOAT MODEL/TYPE _____

HULL NUMBER / CTC... _____

NEW OWNER INFORMATION:

NAME _____

STREET / P.O. BOX _____

CITY / STATE / ZIP CODE _____

DATE PURCHASED ____ / ____ / ____ PHONE # _____

THE CRITERIA LISTED ABOVE **MUST** BE RECEIVED **WITHIN 15 DAYS** OF THE SALE DATE. SUBMIT IT TO CORRECT CRAFT, INC., 14700 AEROSPACE PKWY, ORLANDO, FLORIDA 32832, "ATTENTION WARRANTY DEPARTMENT."

NOTE: Upon verification, the warranty will transfer retroactive to the sale date



NAUTIQUE REGIONAL CENTERS

- - Correct Craft West
11340 White Rock Rd., Suite A.
Rancho Cordova, CA 95742
916/638-3382

- - Correct Craft East
P.O. Box 216
Angola, IN 46703
260/833-2226

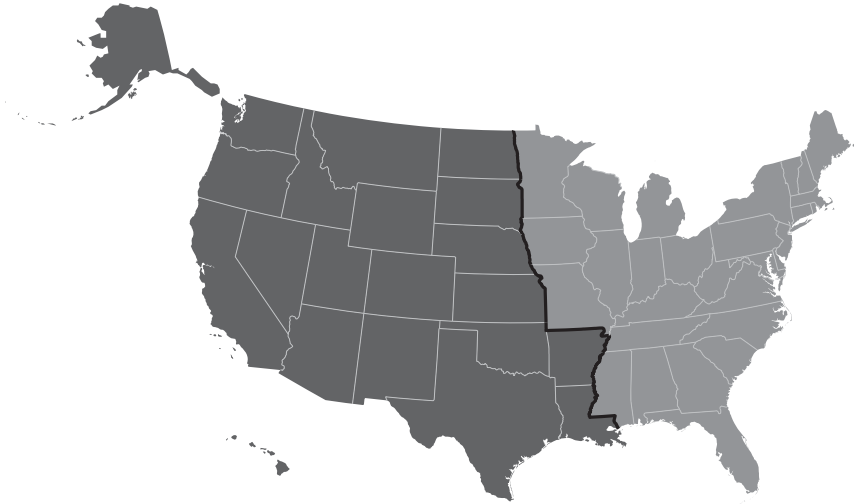

If, for any reason your nearest dealer or the warehouse servicing your territory cannot satisfactorily resolve your problem or answer your questions, then please feel free to contact our Customer Service Department at the main offices of Correct Craft, Inc., either by telephone or by mail.



Dash Plaque Order Form

Custom dash plaques are available for your Nautique. Please check off the shape that matches the year of your boat and mail completed form along with your payment to:

Correct Craft, Inc (Attn: Sales Department)
14700 Aerospace Parkway, Orlando, FL 32832

Method of payment:

Check Money Order Credit Card Type: (Visa or MC only) _____
Card Number: _____ Exp. Date: _____

Desired Saying: (Please Print)

Hull Number: _____

Check Appropriate Model Year:

Please Note: The 1992 Barefoot Nautique does not have a Dash Plaque.

\$6.00 Model Year: 2009 210, 216V, 230, 236 only
(Max. # of characters: 40) 2010 210, 216V, 230, 236 only



\$6.00 Model Year: 2007 210, 236
(Max. # of characters: 40) 2008 210, 230, 236



\$6.00 Model Year: 2004 - 2010
(Max. # of characters: 20)
except 2007 210, 236 & 2008-2010 210, 216V, 230, 236

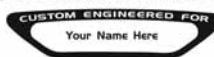

\$6.00 Model Year: 2003
(Max. # of characters: 28)



\$6.00 Model Years: 2000 - 2002
(Max. # of characters: 22)



\$15.00 Model Years: 1998 - 1999
(Max. # of characters: 22)



Please note: This shape is used on the 1997 Ski Nautique

\$15.00 Model Years: 1990 - 1997
(Max. # of characters: 20)



Please note: If ordering a plaque for a 1997 Ski Nautique, order the shape for Model years 1998 - 1999

\$15.00 Model Years: 1987 - 1989
(Max. # of characters: 18)



Plaque will be shipped to: (Please Print)

Name: _____
Address: _____
City: _____ State: _____ Zip: _____

Allow 4 to 6 weeks for the custom plaque order to be processed, made and shipped.

